

Mobile DDR SDRAM

MT46H64M16LF – 16 Meg x 16 x 4 banks

MT46H32M32LF – 8 Meg x 32 x 4 banks

Features

- VDD/VDDQ = 1.70–1.95V
- Bidirectional data strobe per byte of data (DQS)
- Internal, pipelined double data rate (DDR) architecture; two data accesses per clock cycle
- Differential clock inputs (CK and CK#)
- Commands entered on each positive CK edge
- DQS edge-aligned with data for READs; center-aligned with data for WRITEs
- Four internal banks for concurrent operation
- Data masks (DM) for masking write data—one mask per byte
- Programmable burst lengths: 2, 4, 8, or 16¹
- Concurrent auto precharge option is supported
- Auto refresh and self refresh modes
- 1.8V LVCMOS-compatible inputs
- On-chip temperature sensor to control self refresh rate
- Partial-array self refresh (PASR)
- Deep power-down (DPD)
- Status read register (SRR)
- Selectable output drive strength (DS)
- Clock stop capability
- 64ms refresh

Options

- VDD/VDDQ
 - 1.8V/1.8V
- Configuration
 - 64 Meg x 16 (16 Meg x 16 x 4 banks) **64M16**
 - 32 Meg x 32 (8 Meg x 32 x 4 banks) **32M32**

Marking

H

Options (continued)

- Row-size option
 - JEDEC-standard option **LF**
 - Reduced page-size option¹ **LG**
- Plastic “green” package
 - 60-ball VFBGA (10mm x 11.5mm)² **CK**
 - 90-ball VFBGA (10mm x 13mm)³ **CM**
- Timing – cycle time
 - 5ns @ CL = 3 **-5**
 - 5.4ns @ CL = 3 **-54**
 - 6ns @ CL = 3 **-6**
 - 7.5ns @ CL = 3 **-75**
- Power
 - Standard IDD2/IDD6 **None**
 - Low-power IDD2/IDD6 **L**
- Operating temperature range
 - Commercial (0° to +70°C) **None**
 - Industrial (–40°C to +85°C) **IT**
- Revision **:A**

Marking

- Notes: 1. Contact factory for availability.
 2. Only available for x16 configuration.
 3. Only available for x32 configuration.

Table 1: Key Timing Parameters (CL = 3)

Speed Grade	Clock Rate (MHz)	Access Time
-5	200	5.0ns
-54	185	5.0ns
-6	166	5.5ns
-75	133	6.0ns

Table 2: Configuration Addressing

Architecture	64 Meg x 16	32 Meg x 32	Reduced Page-Size Option 32 Meg x 32
Configuration	16 Meg x 16 x 4 banks	8 Meg x 32 x 4 banks	8 Meg x 32 x 4 banks
Refresh count	8K	8K	8K
Row addressing	16K (A[13:0])	8K (A[12:0])	16K (A[13:0])
Column addressing	1K (A[9:0])	1K (A[9:0])	512 (A[8:0])

Table of Contents

Features	1
Options	1
Marking	1
Options (continued)	1
Marking	1
FBGA Part Marking Decoder	5
General Description	5
Functional Block Diagrams	6
Ball Assignments and Descriptions	8
Package Dimensions	12
Electrical Specifications	14
Functional Description	28
Commands	29
DESELECT	30
NO OPERATION (NOP)	30
LOAD MODE REGISTER	30
ACTIVE	30
READ	31
WRITE	31
PRECHARGE	33
BURST TERMINATE	33
AUTO REFRESH	34
SELF REFRESH	34
DEEP POWER-DOWN	35
Operations	36
Initialization	41
Register Definition	43
Mode Registers	43
Standard Mode Register	43
CAS Latency (CL)	46
Extended Mode Register	46
Status Read Register (SRR)	48
Bank/Row Activation	50
Timing Diagrams	51
READs	51
WRITEs	62
PRECHARGE	73
Auto Precharge	74
Concurrent Auto Precharge	74
Auto Refresh	79
Self Refresh	80
Power-Down	81
Deep Power-Down (DPD)	82
Stopping the External Clock	83
Revision History: Device	85
Revision History: Commands, Operations, and Timing Diagrams	87

List of Figures

Figure 1:	1Gb Mobile DDR Part Numbering	5
Figure 2:	Functional Block Diagram (64 Meg x 16)	6
Figure 3:	Functional Block Diagram (32 Meg x 32)	7
Figure 4:	60-Ball VFBGA Assignments – 10mm x 11.5mm (Top View)	8
Figure 5:	90-Ball VFBGA Ball Assignments – 10mm x 13mm (Top View)	9
Figure 6:	60-Ball VFBGA Package	12
Figure 7:	90-Ball VFBGA Package	13
Figure 8:	Typical Self Refresh Current vs. Temperature	20
Figure 9:	ACTIVE Command	30
Figure 10:	READ Command	31
Figure 11:	WRITE Command	32
Figure 12:	PRECHARGE Command	33
Figure 13:	DEEP POWER-DOWN Command	35
Figure 14:	Mobile DRAM Simplified State Diagram	40
Figure 15:	Initialize and Load Mode Registers	42
Figure 16:	Standard Mode Register Definition	43
Figure 17:	CAS Latency	46
Figure 18:	Extended Mode Register	48
Figure 19:	SRR Timing	49
Figure 20:	Status Register Definition	50
Figure 21:	READ Burst	52
Figure 22:	Consecutive READ Bursts	53
Figure 23:	Nonconsecutive READ Bursts	54
Figure 24:	Random READ Accesses	55
Figure 25:	Terminating a READ Burst	56
Figure 26:	READ-to-WRITE	57
Figure 27:	READ-to-PRECHARGE	58
Figure 28:	Data Output Timing – t_{DQSQ} , t_{QH} , and Data Valid Window (x16)	59
Figure 29:	Data Output Timing – t_{DQSQ} , t_{QH} , and Data Valid Window (x32)	60
Figure 30:	Data Output Timing – t_{AC} and t_{DQSK}	61
Figure 31:	Data Input Timing	63
Figure 32:	Write – DM Operation	64
Figure 33:	WRITE Burst	65
Figure 34:	Consecutive WRITE-to-WRITE	66
Figure 35:	Nonconsecutive WRITE-to-WRITE	66
Figure 36:	Random WRITE Cycles	67
Figure 37:	WRITE-to-READ – Uninterrupting	68
Figure 38:	WRITE-to-READ – Interrupting	69
Figure 39:	WRITE-to-READ – Odd Number of Data, Interrupting	70
Figure 40:	WRITE-to-PRECHARGE – Uninterrupting	71
Figure 41:	WRITE-to-PRECHARGE – Interrupting	72
Figure 42:	WRITE-to-PRECHARGE – Odd Number of Data, Interrupting	73
Figure 43:	Bank Read – with Auto Precharge	75
Figure 44:	Bank Read – Without Auto Precharge	76
Figure 45:	Bank Write – with Auto Precharge	77
Figure 46:	Bank Write – Without Auto Precharge	78
Figure 47:	Auto Refresh Mode	79
Figure 48:	Self Refresh Mode	80
Figure 49:	Power-Down Command (in Active or Precharge Modes)	81
Figure 50:	Power-Down Mode (Active or Precharge)	82
Figure 51:	Deep Power-Down	83
Figure 52:	Clock Stop Mode	84

List of Tables

Table 1:	Key Timing Parameters (CL = 3)	1
Table 2:	Configuration Addressing	1
Table 3:	VFBGA Ball Descriptions	10
Table 4:	Absolute Maximum Ratings	14
Table 5:	AC/DC Electrical Characteristics and Operating Conditions	14
Table 6:	Capacitance (x16, x32)	16
Table 7:	IDD Specifications and Conditions (x16)	17
Table 8:	IDD Specifications and Conditions (x32)	18
Table 9:	IDD6 Specifications and Conditions	19
Table 10:	Electrical Characteristics and Recommended AC Operating Conditions	21
Table 11:	Target Output Drive Characteristics (Full Strength)	25
Table 12:	Target Output Drive Characteristics (Three-Quarter Strength)	26
Table 13:	Target Output Drive Characteristics (One-Half Strength)	27
Table 14:	Truth Table – Commands	29
Table 15:	DM Operation Truth Table	29
Table 16:	Truth Table – Current State Bank n – Command to Bank n	36
Table 17:	Truth Table – Current State Bank n – Command to Bank m	37
Table 18:	Truth Table – CKE	39
Table 19:	Burst Definition Table	45

Figure 1: 1Gb Mobile DDR Part Numbering

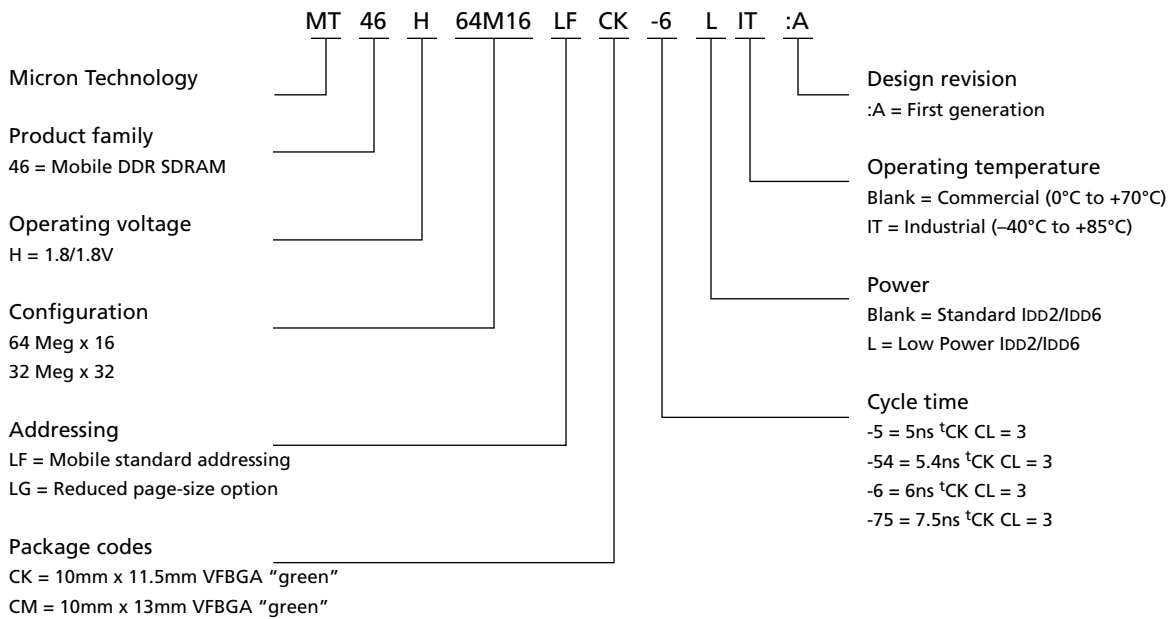

FBGA Part Marking Decoder

Due to space limitations, FBGA-packaged components have an abbreviated part marking that is different from the part number. Micron's FBGA Part Marking Decoder is available at www.micron.com/decoder.

General Description

The 1Gb Mobile DDR SDRAM is a high-speed CMOS, dynamic random-access memory containing 1,073,741,824 bits. It is internally configured as a quad-bank DRAM. Each of the x16's 268,435,456-bit banks is organized as 16,384 rows by 1,024 columns by 16 bits. Each of the x32's 268,435,456-bit banks is organized as 8,192 rows by 1,024 columns by 32 bits. In the reduced page-size (LG) option, each of the x32's 268,435,456-bit banks are organized as 16,384 rows by 512 columns by 32 bits.

- Notes:**
1. Throughout this data sheet, the various figures and text refer to DQs as "DQ." The DQ term is to be interpreted as any and all DQ collectively, unless specifically stated otherwise. Additionally, the x16 is divided into two bytes: the lower byte and the upper byte. For the lower byte (DQ[7:0]), DM refers to LDM and DQS refers to LDQS. For the upper byte (DQ[15:8]), DM refers to UDM and DQS refers to UDQS. The x32 is divided into four bytes. For DQ[7:0], DM refers to DM0 and DQS refers to DQS0. For DQ[15:8], DM refers to DM1 and DQS refers to DQS1. For DQ[23:16], DM refers to DM2 and DQS refers to DQS2. For DQ[31:24], DM refers to DM3 and DQS refers to DQS3.
 2. Complete functionality is described throughout the document; any page or diagram may have been simplified to convey a topic and may not be inclusive of all requirements.
 3. Any specific requirement takes precedence over a general statement.

Functional Block Diagrams

Figure 2: Functional Block Diagram (64 Meg x 16)

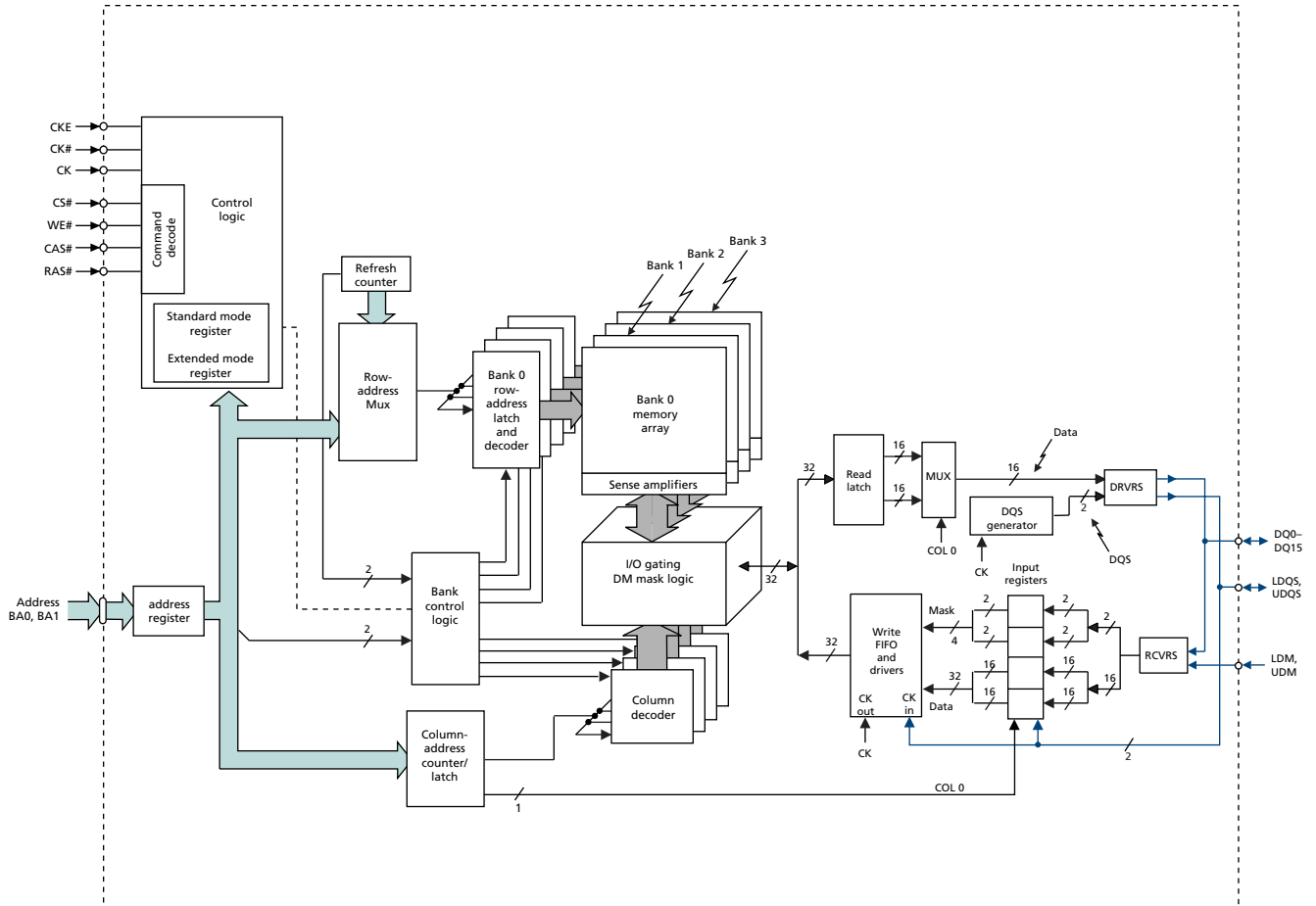
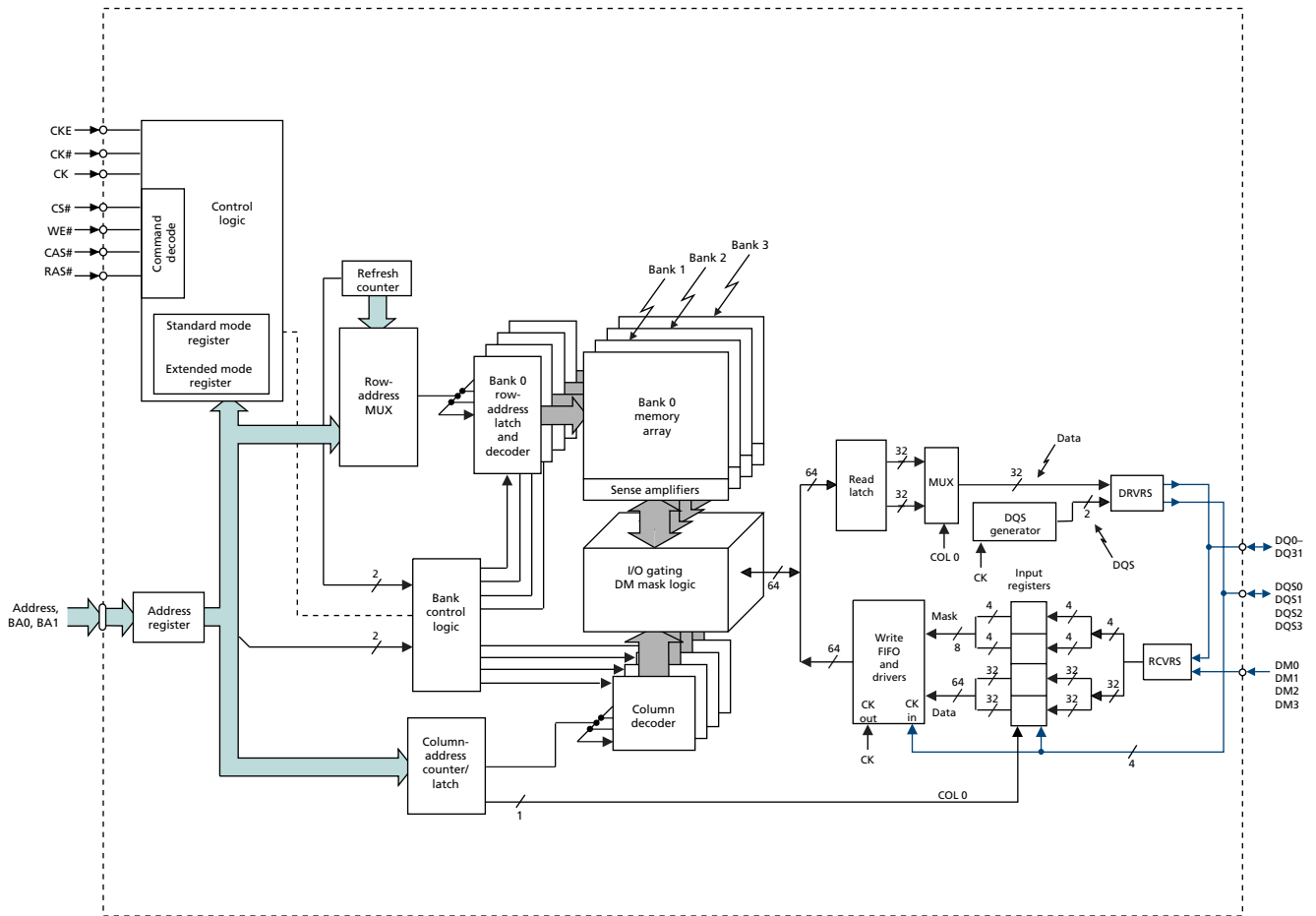
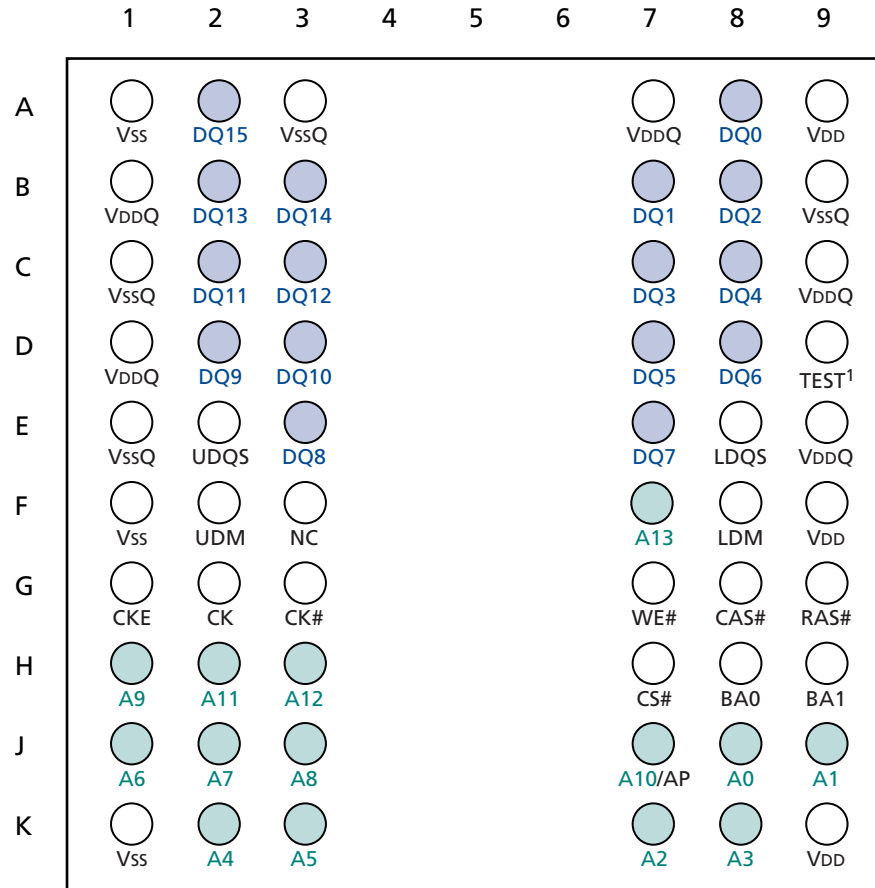

Figure 3: Functional Block Diagram (32 Meg x 32)



Ball Assignments and Descriptions

Figure 4: 60-Ball VFBGA Assignments – 10mm x 11.5mm (Top View)



Notes: 1. D9 is a test pin that must be tied to Vss or VssQ in normal operations.

Figure 5: 90-Ball VFBGA Ball Assignments – 10mm x 13mm (Top View)

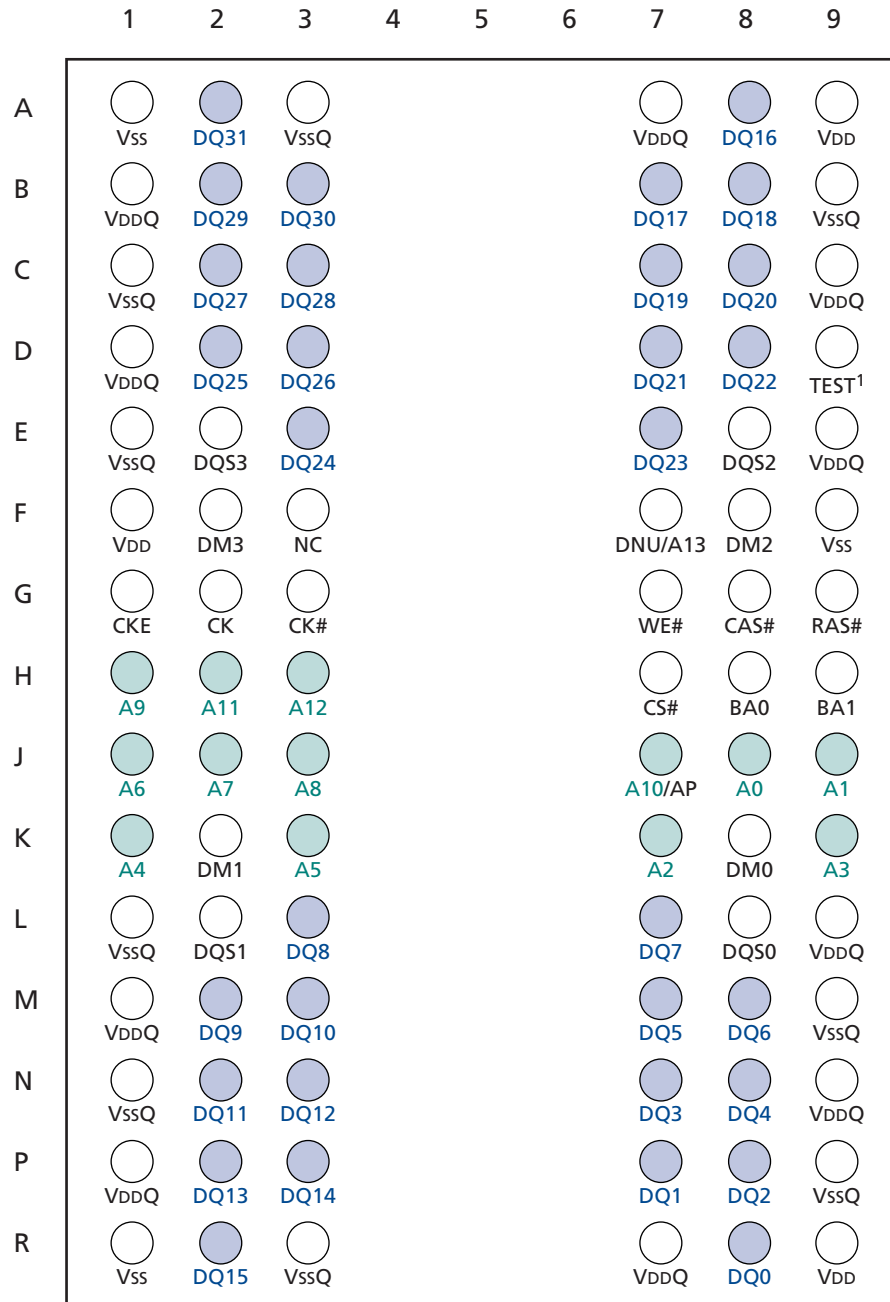

Notes: 1. D9 is a test pin that must be tied to Vss or VssQ in normal operations.

Table 3: VFBGA Ball Descriptions

60-Ball VFBGA	90-Ball VFBGA	Symbol	Type	Description
G2, G3	G2, G3	CK, CK#	Input	Clock: CK is the system clock input. CK and CK# are differential clock inputs. All address and control input signals are sampled on the crossing of the positive edge of CK and the negative edge of CK#. Input and output data is referenced to the crossing of CK and CK# (both directions of the crossing).
G1	G1	CKE	Input	Clock enable: CKE HIGH activates, and CKE LOW deactivates, the internal clock signals, input buffers, and output drivers. Taking CKE LOW enables PRECHARGE power-down and SELF REFRESH operations (all banks idle), or ACTIVE power-down (row active in any bank). CKE is synchronous for all functions except SELF REFRESH exit. All input buffers (except CKE) are disabled during power-down and self refresh modes.
H7	H7	CS#	Input	Chip select: CS# enables (registered LOW) and disables (registered HIGH) the command decoder. All commands are masked when CS# is registered HIGH. CS# provides for external bank selection on systems with multiple banks. CS# is considered part of the command code.
G9, G8, G7	G9, G8, G7	RAS#, CAS#, WE#	Input	Command inputs: RAS#, CAS#, and WE# (along with CS#) define the command being entered.
F2, F8	K8, K2, F8, F2	UDM, LDM (60-ball) DM[3:0] (90-ball)	Input	Input data mask: DM is an input mask signal for write data. Input data is masked when DM is sampled HIGH along with that input data during a WRITE access. DM is sampled on both edges of DQS. Although DM balls are input-only, the DM loading is designed to match that of DQ and DQS balls.
H8, H9	H8, H9	BA0, BA1	Input	Bank address inputs: BA0 and BA1 define to which bank an ACTIVE, READ, WRITE, or PRECHARGE command is being applied. BA0 and BA1 also determine which mode register is loaded during a LOAD MODE REGISTER command.
J8, J9, K7, K8, K2, K3, J1, J2, J3, H1, J7, H2, H3, F7	J8, J9, K7, K9, K1, K3, J1, J2, J3, H1, J7, H2, H3	A[13:0] (60-ball) A[12:0] (90-ball)	Input	Address inputs: Provide the row address for ACTIVE commands, and the column address and auto-precharge bit (A10) for READ or WRITE commands, to select one location out of the memory array in the respective bank. During a PRECHARGE command, A10 determines whether the PRECHARGE applies to one bank (A10 LOW, bank selected by BA0, BA1) or all banks (A10 HIGH). The address inputs also provide the op-code during a LOAD MODE REGISTER command.
A8, B7, B8, C7, C8, D7, D8, E7, E3, D2, D3, C2, C3, B2, B3, A2	R8, P7, P8, N7, N8, M7, M8, L7, L3, M2, M3, N2, N3, P2, P3, R2, A8, B7, B8, C7, C8, D7, D8, E7, E3, D2, D3, C2, C3, B2, B3, A2	DQ[15:0] (60-ball) DQ[31:0] (90-ball)	Input/output	Data input/output: Data bus for x16 and x32.
E8, E2	L8, L2, E8, E2	LDQS, UDQS (60-ball) DQS[3:0] (90-ball)	Input/output	Data strobe: Output with read data, input with write data. DQS is edge-aligned with read data, center-aligned in write data. It is used to capture data.

Table 3: VFBGA Ball Descriptions (Continued)

60-Ball VFBGA	90-Ball VFBGA	Symbol	Type	Description
A7, B1, C9, D1, E9	A7, B1, C9, D1, E9, L9, M1, N9, P1, R7	V _{DDQ}	Supply	DQ power supply.
A3, B9, C1, E1	A3, B9, C1, E1, L1, M9, N1, P9, R3	V _{SSQ}	Supply	DQ ground.
A9, F9, K9	A9, F1, R9	V _{DD}	Supply	Power supply.
A1, F1, K1	A1, F9, R1	V _{SS}	Supply	Ground.
F3	F3	NC	–	No connect: Can be left unconnected.
–	F7	DNU/A13	Input	Do not use. A13 if reduced page-size option is selected; otherwise, DNU.
D9	D9	TEST	Input	Test pin: Must be tied to V _{SS} or V _{SSQ} in normal operations.

Package Dimensions

Figure 6: 60-Ball VFBGA Package

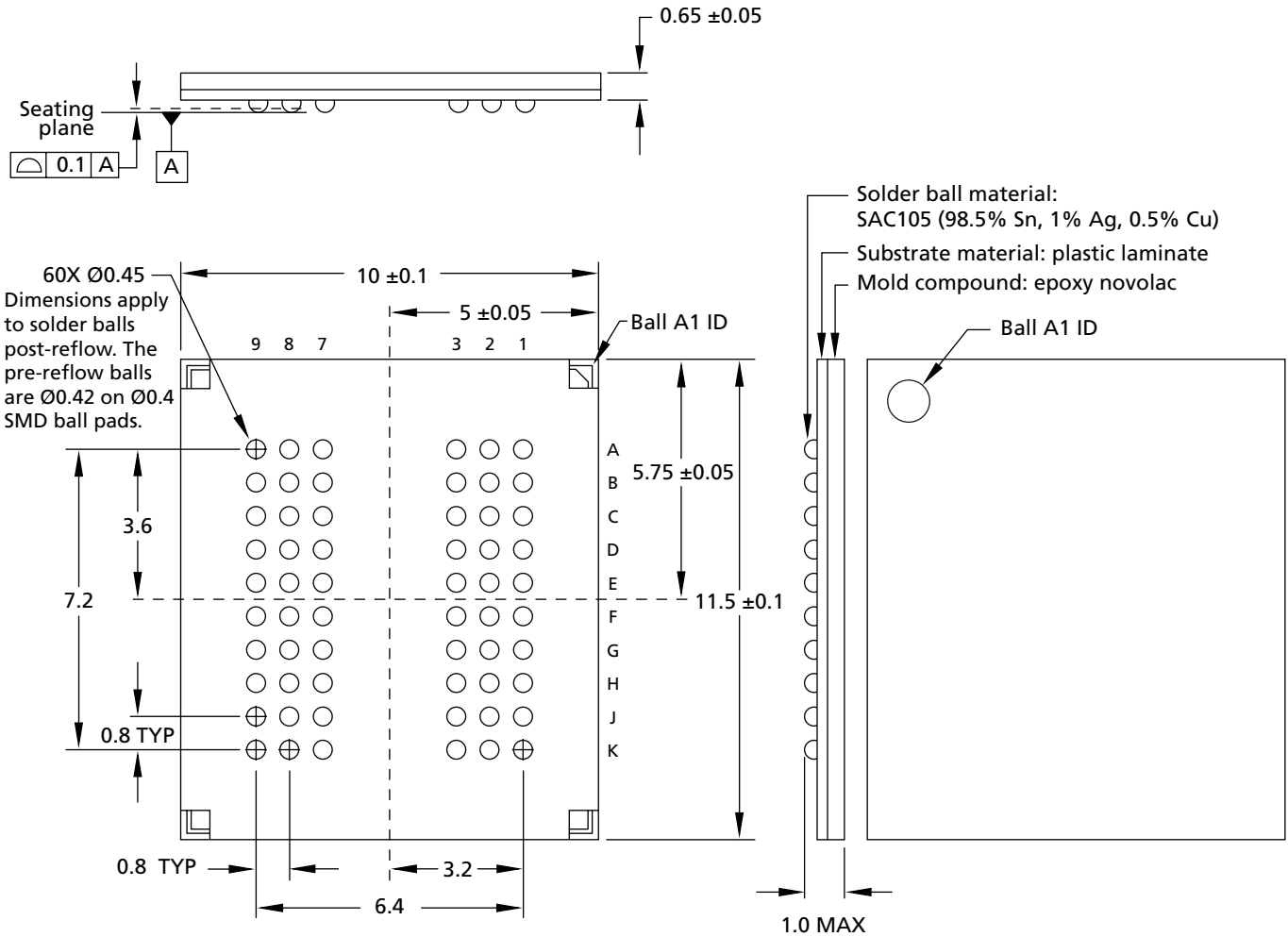
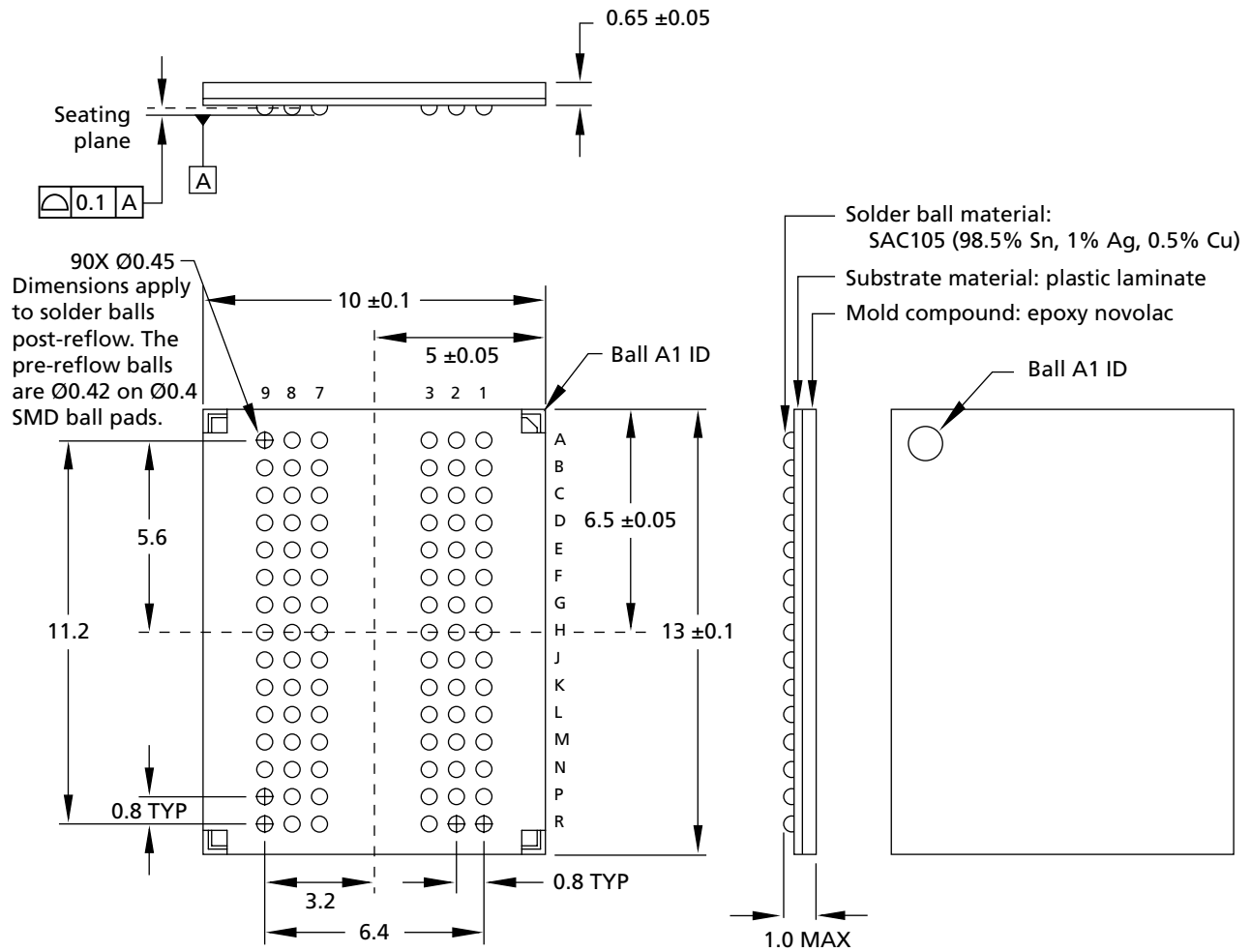

Figure 7: 90-Ball VFBGA Package



- Notes:
1. All dimensions are in millimeters.
 2. Green packaging composition is available upon request.

Electrical Specifications

Stresses greater than those listed in Table 4 may cause permanent damage to the device. This is a stress rating only, and functional operation of the device at these or any other conditions above those indicated in the operational sections of this specification is not implied. Exposure to absolute maximum rating conditions for extended periods may affect reliability.

Table 4: Absolute Maximum Ratings

Note 1 applies to all parameters in this table

Parameter	Symbol	Min	Max	Unit
VDD/VDDQ supply voltage relative to Vss	VDD/VDDQ	-1.0	2.4	V
Voltage on any pin relative to Vss	V _{IN}	-0.5	2.4 or (VDDQ + 0.3V), whichever is less	V
Storage temperature (plastic)	T _{STG}	-55	+150	°C

Notes: 1. VDD and VDDQ must be within 300mV of each other at all times. VDDQ must not exceed VDD.

Table 5: AC/DC Electrical Characteristics and Operating Conditions

Notes: 1-5 apply to all parameters/conditions in this table; VDD/VDDQ = 1.70-1.95V

Parameter/Condition	Symbol	Min	Max	Unit	Notes
Supply voltage	VDD	1.70	1.95	V	6, 7
I/O supply voltage	VDDQ	1.70	1.95	V	6, 7
Address and command inputs					
Input voltage high	V _{IH}	0.8 × VDDQ	VDDQ + 0.3	V	8, 9
Input voltage low	V _{IL}	-0.3	0.2 × VDDQ	V	8, 9
Clock inputs (CK, CK#)					
DC input voltage	V _{IN}	-0.3	VDDQ + 0.3	V	10
DC input differential voltage	V _{ID(DC)}	0.4 × VDDQ	VDDQ + 0.6	V	10, 11
AC input differential voltage	V _{ID(AC)}	0.6 × VDDQ	VDDQ + 0.6	V	10, 11
AC differential crossing voltage	V _{IX}	0.4 × VDDQ	0.6 × VDDQ	V	10, 12
Data inputs					
DC input high voltage	V _{IH(DC)}	0.7 × VDDQ	VDDQ + 0.3	V	8, 9, 13
DC input low voltage	V _{IL(DC)}	-0.3	0.3 × VDDQ	V	8, 9, 13
AC input high voltage	V _{IH(AC)}	0.8 × VDDQ	VDDQ + 0.3	V	8, 9, 13
AC input low voltage	V _{IL(AC)}	-0.3	0.2 × VDDQ	V	8, 9, 13
Data outputs					
DC output high voltage: Logic 1 (I _{OH} = -0.1mA)	V _{OH}	0.9 × VDDQ	-	V	
DC output low voltage: Logic 0 (I _{OL} = 0.1mA)	V _{OL}	-	0.1 × VDDQ	V	
Leakage current					
Input leakage current Any input 0V ≤ V _{IN} ≤ VDD (All other pins not under test = 0V)	I _I	-1	1	μA	
Output leakage current (DQs are disabled; 0V ≤ V _{OUT} ≤ VDDQ)	I _{OZ}	-5	5	μA	

Table 5: AC/DC Electrical Characteristics and Operating Conditions (Continued)

Notes: 1-5 apply to all parameters/conditions in this table; $V_{DD}/V_{DDQ} = 1.70-1.95V$

Parameter/Condition	Symbol	Min	Max	Unit	Notes
Operating temperature					
Commercial	T_A	0	+70	°C	
Industrial	T_A	-40	+85	°C	

- Notes:
1. All voltages referenced to V_{SS} .
 2. All parameters assume proper device initialization.
 3. Tests for AC timing, I_{DD} , and electrical AC and DC characteristics may be conducted at nominal supply voltage levels, but the related specifications and device operation are guaranteed for the full voltage range specified.
 4. Outputs measured with equivalent load; transmission line delay is assumed to be very small:

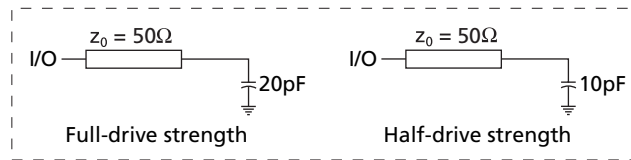

5. Timing and I_{DD} tests may use a V_{IL} -to- V_{IH} swing of up to 1.5V in the test environment, but input timing is still referenced to $V_{DDQ}/2$ (or to the crossing point for CK/CK#). The output timing reference voltage level is $V_{DDQ}/2$.
6. Any positive glitch must be less than 1/3 of the clock cycle and not more than +200mV or 2.0V, whichever is less. Any negative glitch must be less than 1/3 of the clock cycle and not exceed either -150mV or +1.6V, whichever is more positive.
7. V_{DD} and V_{DDQ} must track each other and V_{DDQ} must be less than or equal to V_{DD} .
8. To maintain a valid level, the transitioning edge of the input must:
 - 8a. Sustain a constant slew rate from the current AC level through to the target AC level, $V_{IL(AC)}$ or $V_{IH(AC)}$.
 - 8b. Reach at least the target AC level.
 - 8c. After the AC target level is reached, continue to maintain at least the target DC level, $V_{IL(DC)}$ or $V_{IH(DC)}$.
9. V_{IH} overshoot: $V_{IH} (MAX) = V_{DDQ} + 1.0V$ for a pulse width $\leq 3ns$ and the pulse width cannot be greater than 1/3 of the cycle rate. V_{IL} undershoot: $V_{IL} (MIN) = -1.0V$ for a pulse width $\leq 3ns$ and the pulse width cannot be greater than 1/3 of the cycle rate.
10. CK and CK# input slew rate must be ≥ 1 V/ns (2 V/ns if measured differentially).
11. V_{ID} is the magnitude of the difference between the input level on CK and the input level on CK#.
12. The value of V_{IX} is expected to equal $V_{DDQ}/2$ of the transmitting device and must track variations in the DC level of the same.
13. DQ and DM input slew rates must not deviate from DQS by more than 10 percent. 50ps must be added to t_{DS} and t_{DH} for each 100 mV/ns reduction in slew rate. If slew rate exceeds 4 V/ns, functionality is uncertain.

Table 6: Capacitance (x16, x32)

Note 1 applies to all the parameters in this table

Parameter	Symbol	Min	Max	Unit	Notes
Input capacitance: CK, CK#	CCK	1.5	3.0	pF	
Delta input capacitance: CK, CK#	CDCK	–	0.25	pF	2
Input capacitance: command and address	CI	1.5	3.0	pF	
Delta input capacitance: command and address	CDI	–	0.5	pF	2
Input/output capacitance: DQs, DQS, DM	CIO	1.5	4.5	pF	
Delta input/output capacitance: DQs, DQS, DM	CDIO	–	0.5	pF	3

- Notes:
1. This parameter is sampled. $V_{DD}/V_{DDQ} = 1.70\text{--}1.95\text{V}$, $f = 100\text{ MHz}$, $T_A = 25^\circ\text{C}$, $V_{OUT(DC)} = V_{DDQ}/2$, V_{OUT} (peak-to-peak) = 0.2V. DM input is grouped with I/O pins, reflecting the fact that they are matched in loading.
 2. The input capacitance per pin group will not differ by more than this maximum amount for any given device.
 3. The I/O capacitance per DQS and DQ byte/group will not differ by more than this maximum amount for any given device.

Table 7: IDD Specifications and Conditions (x16)

Notes: 1–5 apply to all the parameters/conditions in this table; notes appear on page 19;
VDD/VDDQ = 1.70–1.95V

Parameter/Condition	Symbol	Max				Unit	Notes	
		-5	-54	-6	-75			
Operating one bank active-precharge current: $t_{RC} = t_{RC} (MIN)$; $t_{CK} = t_{CK} (MIN)$; CKE is HIGH; CS is HIGH between valid commands; Address inputs are switching every two clock cycles; Data bus inputs are stable	IDD0	80	75	70	60	mA	6	
Precharge power-down standby current: All banks idle; CKE is LOW; CS is HIGH; $t_{CK} = t_{CK} (MIN)$; Address and control inputs are switching; Data bus inputs are stable	IDD2P	600				μA	7, 8	
Precharge power-down standby current: Clock stopped; All banks idle; CKE is LOW; CS is HIGH; CK = LOW, CK# = HIGH; Address and control inputs are switching; Data bus inputs are stable	IDD2PS	600				μA	7	
Precharge nonpower-down standby current: All banks idle; CKE = HIGH; CS = HIGH; $t_{CK} = t_{CK} (MIN)$; Address and control inputs are switching; Data bus inputs are stable	IDD2N	18	17	15	12	mA	9	
Precharge nonpower-down standby current: Clock stopped; All banks idle; CKE = HIGH; CS = HIGH; CK = LOW, CK# = HIGH; Address and control inputs are switching; Data bus inputs are stable	IDD2NS	14	13	8	8	mA	9	
Active power-down standby current: One bank active; CKE = LOW; CS = HIGH; $t_{CK} = t_{CK} (MIN)$; Address and control inputs are switching; Data bus inputs are stable	IDD3P	3.6				mA	8	
Active power-down standby current: Clock stopped; One bank active; CKE = LOW; CS = HIGH; CK = LOW; CK# = HIGH; Address and control inputs are switching; Data bus inputs are stable	IDD3PS	3.6				mA		
Active nonpower-down standby: One bank active; CKE = HIGH; CS = HIGH; $t_{CK} = t_{CK} (MIN)$; Address and control inputs are switching; Data bus inputs are stable	IDD3N	20	19	18	16	mA	6	
Active nonpower-down standby: Clock stopped; One bank active; CKE = HIGH; CS = HIGH; CK = LOW; CK# = HIGH; Address and control inputs are switching; Data bus inputs are stable	IDD3NS	14	14	14	12	mA	6	
Operating burst read: One bank active; BL = 4; $t_{CK} = t_{CK} (MIN)$; Continuous READ bursts; IOUT = 0mA; Address inputs are switching every two clock cycles; 50 percent data changing each burst	IDD4R	130	125	115	105	mA	6	
Operating burst write: One bank active; BL = 4; $t_{CK} = t_{CK} (MIN)$; Continuous WRITE bursts; Address inputs are switching; 50 percent data changing each burst	IDD4W	130	125	115	105	mA	6	
Auto refresh: Burst refresh; CKE = HIGH; Address and control inputs are switching; Data bus inputs are stable	$t_{RFC} = 138ns$	IDD5	140	140	140	140	mA	10
	$t_{RFC} = t_{REFI}$	IDD5A	15	15	15	14	mA	10, 11
Deep power-down current: Address and control balls are stable; Data bus inputs are stable	IDD8	10				μA	7, 13	

Table 8: IDD Specifications and Conditions (x32)

Notes: 1–5 apply to all parameters/conditions in this table; notes appear on page 19;
VDD/VDDQ = 1.70–1.95V

Parameter/Condition	Symbol	Max				Unit	Notes	
		-5	-54	-6	-75			
Operating one bank active-precharge current: $t_{RC} = t_{RC}(\text{MIN})$; $t_{CK} = t_{CK}(\text{MIN})$; CKE is HIGH; CS is HIGH between valid commands; Address inputs are switching every two clock cycles; Data bus inputs are stable	JEDEC-standard option	IDD0	110	105	100	70	mA	6
	Reduced page-size option		80	75	70	60	mA	6
Precharge power-down standby current: All banks idle; CKE is LOW; CS is HIGH; $t_{CK} = t_{CK}(\text{MIN})$; Address and control inputs are switching; Data bus inputs are stable	IDD2P	600				μA	7, 8	
Precharge power-down standby current: Clock stopped; All banks idle; CKE is LOW; CS is HIGH, CK = LOW, CK# = HIGH; Address and control inputs are switching; Data bus inputs are stable	IDD2PS	600				μA	7	
Precharge nonpower-down standby current: All banks idle; CKE = HIGH; CS = HIGH; $t_{CK} = t_{CK}(\text{MIN})$; Address and control inputs are switching; Data bus inputs are stable	IDD2N	18	17	15	12	mA	9	
Precharge nonpower-down standby current: Clock stopped; All banks idle; CKE = HIGH; CS = HIGH; CK = LOW, CK# = HIGH; Address and control inputs are switching; Data bus inputs are stable	IDD2NS	14	13	8	8	mA	9	
Active power-down standby current: One bank active; CKE = LOW; CS = HIGH; $t_{CK} = t_{CK}(\text{MIN})$; Address and control inputs are switching; Data bus inputs are stable	IDD3P	3.6				mA	8	
Active power-down standby current: Clock stopped; One bank active; CKE = LOW; CS = HIGH; CK = LOW; CK# = HIGH; Address and control inputs are switching; Data bus inputs are stable	IDD3PS	3.6				mA		
Active nonpower-down standby: One bank active; CKE = HIGH; CS = HIGH; $t_{CK} = t_{CK}(\text{MIN})$; Address and control inputs are switching; Data bus inputs are stable	IDD3N	20	19	18	16	mA	6	
Active nonpower-down standby: Clock stopped; One bank active; CKE = HIGH; CS = HIGH; CK = LOW; CK# = HIGH; Address and control inputs are switching; Data bus inputs are stable	IDD3NS	16	15	14	12	mA	6	
Operating burst read: One bank active; BL = 4; CL = 3; $t_{CK} = t_{CK}(\text{MIN})$; Continuous READ bursts; IOUT = 0mA; Address inputs are switching every two clock cycles; 50 percent data changing each burst	IDD4R	150	145	140	120	mA	6	
Operating burst write: One bank active; BL = 4; $t_{CK} = t_{CK}(\text{MIN})$; Continuous WRITE bursts; Address inputs are switching; 50 percent data changing each burst	IDD4W	150	145	140	120	mA	6	
Auto refresh: Burst refresh; CKE = HIGH; Address and control inputs are switching; Data bus inputs are stable	$t_{RFC} = 138\text{ns}$	IDD5	140	140	140	140	mA	10
	$t_{RFC} = t_{REFI}$	IDD5A	15	15	15	14	mA	10, 11
Deep power-down current: Address and control pins are stable; Data bus inputs are stable	IDD8	10				μA	7, 13	

Table 9: IDD6 Specifications and Conditions

 Notes: 1–5, 7, and 12; apply to all the parameters/conditions in this table; $V_{DD}/V_{DDQ} = 1.70\text{--}1.95V$

Parameter/Condition	Symbol	Low Power	Standard	Units	
Self refresh: CKE = LOW; $t_{CK} = t_{CK}(\text{MIN})$; Address and control inputs are stable; Data bus inputs are stable	IDD6	Full array, 85°C	1,000	1,200	μA
		Full array, 45°C	500	750	μA
		1/2 array, 85°C	750	900	μA
		1/2 array, 45°C	440	730	μA
		1/4 array, 85°C	600	750	μA
		1/4 array, 45°C	380	680	μA
		1/8 array, 85°C	550	750	μA
		1/8 array, 45°C	350	620	μA
		1/16 array, 85°C	500	700	μA
		1/16 array, 45°C	330	540	μA

- Notes:
- All voltages referenced to V_{SS} .
 - Tests for IDD characteristics may be conducted at nominal supply voltage levels, but the related specifications and device operation are guaranteed for the full voltage range specified.
 - Timing and IDD tests may use a V_{IL} -to- V_{IH} swing of up to 1.5V in the test environment, but input timing is still referenced to $V_{DDQ}/2$ (or to the crossing point for CK/CK#). The output timing reference voltage level is $V_{DDQ}/2$.
 - IDD is dependent on output loading and cycle rates. Specified values are obtained with minimum cycle time with the outputs open.
 - IDD specifications are tested after the device is properly initialized and values are averaged at the defined cycle rate.
 - MIN (t_{RC} or t_{RFC}) for IDD measurements is the smallest multiple of t_{CK} that meets the minimum absolute value for the respective parameter. $t_{RAS}(\text{MAX})$ for IDD measurements is the largest multiple of t_{CK} that meets the maximum absolute value for t_{RAS} .
 - Measurement is taken 500ms after entering into this operating mode to provide settling time for the tester.
 - V_{DD} must not vary more than 4 percent if CKE is not active while any bank is active.
 - IDD2N specifies DQ, DQS, and DM to be driven to a valid HIGH or LOW logic level.
 - CKE must be active (HIGH) during the entire time a REFRESH command is executed. From the time the AUTO REFRESH command is registered, CKE must be active at each rising clock edge until t_{RFC} later.
 - This limit is a nominal value and does not result in a fail. CKE is HIGH during REFRESH command period ($t_{RFC}[\text{MIN}]$) else CKE is LOW (for example, during standby).
 - Values for IDD6 85°C are guaranteed for the entire temperature range. All other IDD6 values are estimated.
 - Typical values at 25°C, not a maximum value.

Figure 8: Typical Self Refresh Current vs. Temperature

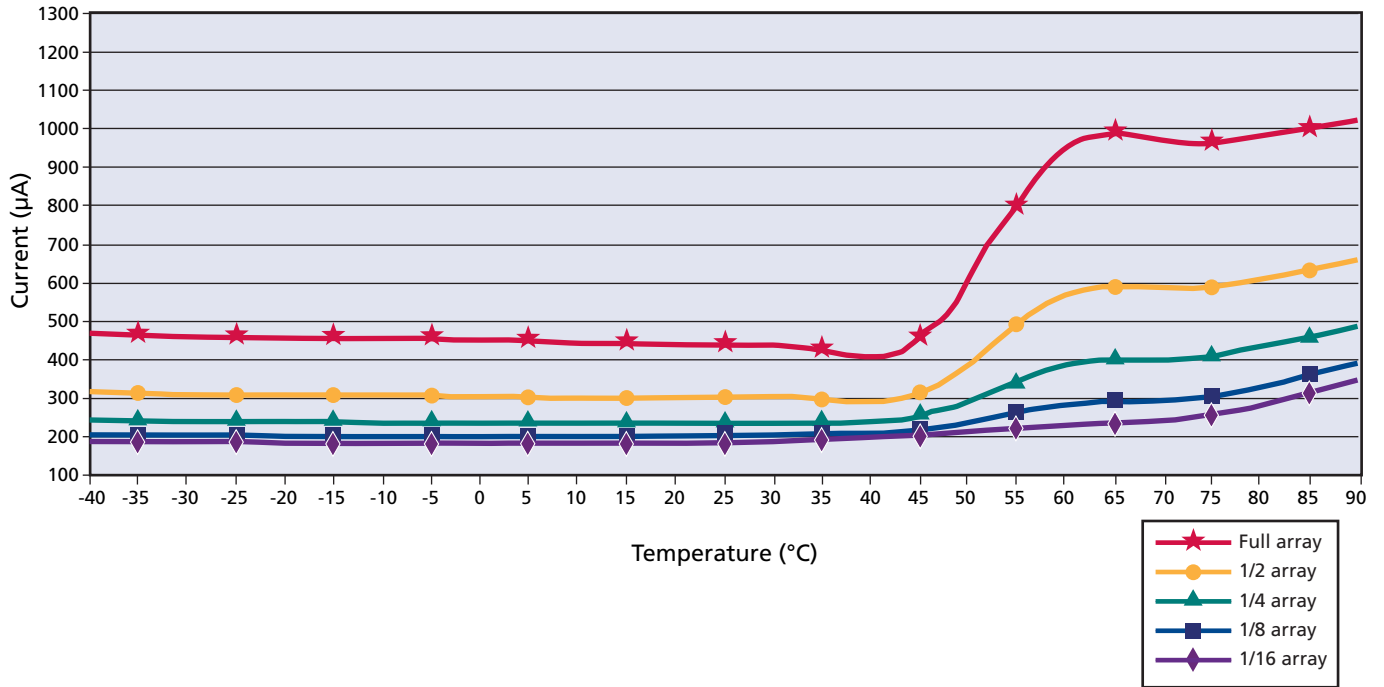

Table 10: Electrical Characteristics and Recommended AC Operating Conditions

Notes: 1–9 apply to all the parameters in this table; VDD/VDDQ = 1.70–1.95V

Parameter	Symbol	-5		-54		-6		-75		Unit	Notes	
		Min	Max	Min	Max	Min	Max	Min	Max			
Access window of DQs from CK/CK#	CL = 3	t_{AC}	2.0	5.0	2.0	5.0	2.0	5.5	2.0	6.0	ns	
	CL = 2		2.0	6.5	2.0	6.5	2.0	6.5	2.0	6.5		
Clock cycle time	CL = 3	t_{CK}	5	–	5.4	–	6	–	7.5	–	ns	10
	CL = 2		12	–	12	–	12	–	12	–		
CK high-level width		t_{CH}	0.45	0.55	0.45	0.55	0.45	0.55	0.45	0.55	t_{CK}	
CK low-level width		t_{CL}	0.45	0.55	0.45	0.55	0.45	0.55	0.45	0.55	t_{CK}	
CKE minimum pulse width (high and low)		t_{CKE}	1	–	1	–	1	–	1	–	t_{CK}	
Auto precharge write recovery + precharge time		t_{DAL}	–	–	–	–	–	–	–	–	–	11
DQ and DM input hold time relative to DQS (fast slew rate)		t_{DH_f}	0.6	–	0.6	–	0.6	–	0.8	–	ns	12, 13, 14
DQ and DM input hold time relative to DQS (slow slew rate)		t_{DH_s}	0.7	–	0.7	–	0.7	–	0.9	–	ns	
DQ and DM input setup time relative to DQS (fast slew rate)		t_{DS_f}	0.6	–	0.6	–	0.6	–	0.8	–	ns	12, 13, 14
DQ and DM input setup time relative to DQS (slow slew rate)		t_{DS_s}	0.7	–	0.7	–	0.7	–	0.9	–	ns	
DQ and DM input pulse width (for each input)		t_{DIPW}	1.8	–	1.9	–	2.1	–	1.8	–	ns	15
Access window of DQS from CK/CK#	CL = 3	t_{DQSK}	2.0	5.0	2.0	5.0	2.0	5.5	2.0	6.0	ns	
	CL = 2		2.0	6.5	2.0	6.5	2.0	6.5	2.0	6.5	ns	
DQS input high pulse width		t_{DQSH}	0.4	0.6	0.4	0.6	0.4	0.6	0.4	0.6	t_{CK}	
DQS input low pulse width		t_{DQSL}	0.4	0.6	0.4	0.6	0.4	0.6	0.4	0.6	t_{CK}	
DQS–DQ skew, DQS to last DQ valid, per group, per access		t_{DQSQ}	–	0.4	–	0.45	–	0.45	–	0.6	ns	12, 16
WRITE command to first DQS latching transition		t_{DQSS}	0.75	1.25	0.75	1.25	0.75	1.25	0.75	1.25	t_{CK}	
DQS falling edge from CK rising – hold time		t_{DSH}	0.2	–	0.2	–	0.2	–	0.2	–	t_{CK}	
DQS falling edge to CK rising – setup time		t_{DSS}	0.2	–	0.2	–	0.2	–	0.2	–	t_{CK}	
Data valid output window (DVW)	n/a	$t_{QH} - t_{DQSQ}$	$t_{QH} - t_{DQSQ}$	$t_{QH} - t_{DQSQ}$	$t_{QH} - t_{DQSQ}$	$t_{QH} - t_{DQSQ}$	$t_{QH} - t_{DQSQ}$	$t_{QH} - t_{DQSQ}$	$t_{QH} - t_{DQSQ}$	$t_{QH} - t_{DQSQ}$	ns	16
Half-clock period		t_{HP}	t_{CH}, t_{CL}	–	t_{CH}, t_{CL}	–	t_{CH}, t_{CL}	–	t_{CH}, t_{CL}	–	ns	17
Data-out High-Z window from CK/CK#	CL = 3	t_{HZ}	–	5.0	–	5.0	–	5.5	–	6.0	ns	18, 19
	CL = 2		–	6.5	–	6.5	–	6.5	–	6.5	ns	
Data-out Low-Z window from CK/CK#		t_{LZ}	1.0	–	1.0	–	1.0	–	1.0	–	ns	18
Address and control input hold time (fast slew rate)		t_{IH_f}	0.9	–	1.0	–	1.1	–	1.3	–	ns	14, 20
Address and control input hold time (slow slew rate)		t_{IH_s}	1.1	–	1.2	–	1.2	–	1.5	–	ns	

Table 10: Electrical Characteristics and Recommended AC Operating Conditions (Continued)

Notes: 1–9 apply to all the parameters in this table; VDD/VDDQ = 1.70–1.95V

Parameter	Symbol	-5		-54		-6		-75		Unit	Notes
		Min	Max	Min	Max	Min	Max	Min	Max		
Address and control input setup time (fast slew rate)	t_{ISF}	0.9	–	1.0	–	1.1	–	1.3	–	ns	14, 20
Address and control input setup time (slow slew rate)	t_{ISs}	1.1	–	1.2	–	1.2	–	1.5	–	ns	
Address and control input pulse width	t_{IPW}	2.3	–	2.5	–	2.6	–	$t_{IS} + t_{IH}$	–	ns	15
LOAD MODE REGISTER command cycle time	t_{MRD}	2	–	2	–	2	–	2	–	t_{CK}	
DQ–DQS hold, DQS to first DQ to go non-valid, per access	t_{QH}	$t_{HP} - t_{QHS}$	–	$t_{HP} - t_{QHS}$	–	$t_{HP} - t_{QHS}$	–	$t_{HP} - t_{QHS}$	–	ns	12, 16
Data hold skew factor	t_{QHS}	–	0.5	–	0.5	–	0.65	–	0.75	ns	
ACTIVE-to-PRECHARGE command	t_{RAS}	40	70,000	42	70,000	42	70,000	45	70,000	ns	21
ACTIVE-to-ACTIVE/ACTIVE-to-AUTO REFRESH command period	t_{RC}	55	–	58.2	–	60	–	75	–	ns	
ACTIVE-to-READ or WRITE delay	t_{RCD}	15	–	16.2	–	18	–	22.5	–	ns	
Refresh period	t_{REF}	–	64	–	64	–	64	–	64	ms	
Average periodic refresh interval	t_{REFI}	–	7.8	–	7.8	–	7.8	–	7.8	μs	22
AUTO REFRESH command period	t_{RFC}	110	–	110	–	110	–	110	–	ns	
PRECHARGE command period	t_{RP}	15	–	16.2	–	18	–	22.5	–	ns	
DQS read preamble	CL = 3 t_{RPRE}	0.9	1.1	0.9	1.1	0.9	1.1	0.9	1.1	t_{CK}	
	CL = 2 t_{RPRE}	0.5	1.1	0.5	1.1	0.5	1.1	0.5	1.1	t_{CK}	
DQS read postamble	t_{RPST}	0.4	0.6	0.4	0.6	0.4	0.6	0.4	0.6	t_{CK}	
ACTIVE bank <i>a</i> to ACTIVE bank <i>b</i> command	t_{RRD}	10	–	10.8	–	12	–	15	–	ns	
Read of SRR to next valid command	t_{SRC}	CL + 1	–	CL + 1	–	CL + 1	–	CL + 1	–	t_{CK}	
SRR-to-READ	t_{SRR}	2	–	2	–	2	–	2	–	t_{CK}	
DQS write preamble	t_{WPRE}	0.25	–	0.25	–	0.25	–	0.25	–	t_{CK}	
DQS write preamble setup time	t_{WPRES}	0	–	0	–	0	–	0	–	ns	23, 24
DQS write postamble	t_{WPST}	0.4	0.6	0.4	0.6	0.4	0.6	0.4	0.6	t_{CK}	25
Write recovery time	t_{WR}	15	–	15	–	15	–	15	–	ns	26
Internal WRITE-to-READ command delay	t_{WTR}	2	–	2	–	1	–	1	–	t_{CK}	
Exit power-down mode to first valid command	t_{XP}	2	–	2	–	2	–	2	–	t_{CK}	
Exit SELF REFRESH to first valid command	t_{XSR}	138	–	138	–	138	–	138	–	ns	27

- Notes:
1. All voltages referenced to Vss.
 2. All parameters assume proper device initialization.
 3. Tests for AC timing and electrical AC and DC characteristics may be conducted at nominal supply voltage levels, but the related specifications and device operation are guaranteed for the full voltage ranges specified.
 4. The circuit shown below represents the timing reference load used in defining the relevant timing parameters of the device. It is not intended to be either a precise representation of the typical system environment or a depiction of the actual load presented by a production tester. System designers will use IBIS or other simulation tools to correlate the timing reference load to system environment. Specifications are correlated to production test condi-

tions (generally a coaxial transmission line terminated at the tester electronics). For the half-strength driver with a nominal 10pF load, parameters t_{AC} and t_{QH} are expected to be in the same range. However, these parameters are not subject to production test but are estimated by design/characterization. Use of IBIS or other simulation tools for system design validation is suggested.

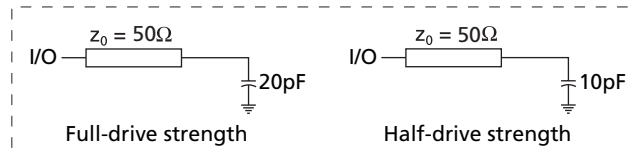

5. The CK/CK# input reference voltage level (for timing referenced to CK/CK#) is the point at which CK and CK# cross; the input reference voltage level for signals other than CK/CK# is $V_{DDQ}/2$.
6. A CK and CK# input slew rate ≥ 1 V/ns (2 V/ns if measured differentially) is assumed for all parameters.
7. All AC timings assume an input slew rate of 1 V/ns.
8. CAS latency definition: with CL = 2, the first data element is valid at ($t_{CK} + t_{AC}$) after the clock at which the READ command was registered; for CL = 3, the first data element is valid at ($2 \times t_{CK} + t_{AC}$) after the first clock at which the READ command was registered.
9. Timing tests may use a V_{IL} -to- V_{IH} swing of up to 1.5V in the test environment, but input timing is still referenced to $V_{DDQ}/2$ or to the crossing point for CK/CK#. The output timing reference voltage level is $V_{DDQ}/2$.
10. Clock frequency change is supported only during a clock stop, power-down, or self-refresh mode.
11. $t_{DAL} = (t_{WR}/t_{CK}) + (t_{RP}/t_{CK})$: for each term, if not already an integer, round to the next higher integer.
12. Referenced to each output group: for x16, LDQS with DQ[7:0]; and UDQS with DQ[15:8]. For x32, DQS0 with DQ[7:0]; DQS1 with DQ[15:8]; DQS2 with DQ[23:16]; and DQS3 with DQ[31:24].
13. DQ and DM input slew rates must not deviate from DQS by more than 10 percent. If the DQ/DM/DQS slew rate is less than 1.0 V/ns, timing must be derated: 50ps must be added to t_{DS} and t_{DH} for each 100 mV/ns reduction in slew rate. If slew rate exceeds 4 V/ns, functionality is uncertain.
14. The transition time for input signals (CAS#, CKE, CS#, DM, DQ, DQS, RAS#, WE#, and addresses) are measured between $V_{IL}(DC)$ to $V_{IH}(AC)$ for rising input signals and $V_{IH}(DC)$ to $V_{IL}(AC)$ for falling input signals.
15. These parameters guarantee device timing but are not tested on each device.
16. The valid data window is derived by achieving other specifications: t_{HP} ($t_{CK}/2$), t_{DQSQ} , and t_{QH} ($t_{HP} - t_{QHS}$). The data valid window derates directly proportional with the clock duty cycle and a practical data valid window can be derived. The clock is provided a maximum duty cycle variation of 45/55. Functionality is uncertain when operating beyond a 45/55 ratio.
17. t_{HP} (MIN) is the lesser of t_{CL} (MIN) and t_{CH} (MIN) actually applied to the device CK and CK# inputs, collectively.
18. t_{HZ} and t_{LZ} transitions occur in the same access time windows as valid data transitions. These parameters are not referenced to a specific voltage level, but specify when the device output is no longer driving (t_{HZ}) or begins driving (t_{LZ}).
19. t_{HZ} (MAX) will prevail over t_{DQSCK} (MAX) + t_{RPST} (MAX) condition.
20. Fast command/address input slew rate ≥ 1 V/ns. Slow command/address input slew rate ≥ 0.5 V/ns. If the slew rate is less than 0.5 V/ns, timing must be derated: t_{IS} has an additional 50ps per each 100 mV/ns reduction in slew rate from the 0.5 V/ns. t_{IH} has 0ps added, therefore, it remains constant. If the slew rate exceeds 4.5 V/ns, functionality is uncertain.

21. READs and WRITEs with auto precharge must not be issued until t^{RAS} (MIN) can be satisfied prior to the internal PRECHARGE command being issued.
22. The refresh period equals 64ms. This equates to an average refresh rate of 7.8125 μ s.
23. This is not a device limit. The device will operate with a negative value, but system performance could be degraded due to bus turnaround.
24. It is recommended that DQS be valid (HIGH or LOW) on or before the WRITE command. The case shown (DQS going from High-Z to logic LOW) applies when no WRITEs were previously in progress on the bus. If a previous WRITE was in progress, DQS could be HIGH during this time, depending on t^{DQSS} .
25. The maximum limit for this parameter is not a device limit. The device will operate with a greater value for this parameter, but system performance (bus turnaround) will degrade accordingly.
26. At least one clock cycle is required during t^{WR} time when in auto precharge mode.
27. Clock must be toggled a minimum of two times during the t^{XSR} period.

Table 11: Target Output Drive Characteristics (Full Strength)

Notes 1–2 apply to all values. Characteristics are specified under best and worst process variations/conditions

Voltage (V)	Pull-Down Current (mA)		Pull-Up Current (mA)	
	Min	Max	Min	Max
0.00	0.00	0.00	0.00	0.00
0.10	2.80	18.53	-2.80	-18.53
0.20	5.60	26.80	-5.60	-26.80
0.30	8.40	32.80	-8.40	-32.80
0.40	11.20	37.05	-11.20	-37.05
0.50	14.00	40.00	-14.00	-40.00
0.60	16.80	42.50	-16.80	-42.50
0.70	19.60	44.57	-19.60	-44.57
0.80	22.40	46.50	-22.40	-46.50
0.85	23.80	47.48	-23.80	-47.48
0.90	23.80	48.50	-23.80	-48.50
0.95	23.80	49.40	-23.80	-49.40
1.00	23.80	50.05	-23.80	-50.05
1.10	23.80	51.35	-23.80	-51.35
1.20	23.80	52.65	-23.80	-52.65
1.30	23.80	53.95	-23.80	-53.95
1.40	23.80	55.25	-23.80	-55.25
1.50	23.80	56.55	-23.80	-56.55
1.60	23.80	57.85	-23.80	-57.85
1.70	23.80	59.15	-23.80	-59.15
1.80	-	60.45	-	-60.45
1.90	-	61.75	-	-61.75

- Notes: 1. Table values based on nominal impedance of 25Ω (full-drive) at $V_{DDQ}/2$.
 2. The full variation in drive current, from minimum to maximum—due to process, voltage, and temperature—will lie within the outer bounding lines of the I-V curves.

Table 12: Target Output Drive Characteristics (Three-Quarter Strength)

Notes 1–3 apply to all values. Characteristics are specified under best and worst process variations/conditions.

Voltage (V)	Pull-Down Current (mA)		Pull-Up Current (mA)	
	Min	Max	Min	Max
0.00	0.00	0.00	0.00	0.00
0.10	1.96	12.97	-1.96	-12.97
0.20	3.92	18.76	-3.92	-18.76
0.30	5.88	22.96	-5.88	-22.96
0.40	7.84	25.94	-7.84	-25.94
0.50	9.80	28.00	-9.80	-28.00
0.60	11.76	29.75	-11.76	-29.75
0.70	13.72	31.20	-13.72	-31.20
0.80	15.68	32.55	-15.68	-32.55
0.85	16.66	33.24	-16.66	-33.24
0.90	16.66	33.95	-16.66	-33.95
0.95	16.66	34.58	-16.66	-34.58
1.00	16.66	35.04	-16.66	-35.04
1.10	16.66	35.95	-16.66	-35.95
1.20	16.66	36.86	-16.66	-36.86
1.30	16.66	37.77	-16.66	-37.77
1.40	16.66	38.68	-16.66	-38.68
1.50	16.66	39.59	-16.66	-39.59
1.60	16.66	40.50	-16.66	-40.50
1.70	16.66	41.41	-16.66	-41.41
1.80	–	42.32	–	-42.32
1.90	–	43.23	–	-43.23

- Notes:
1. Table values based on nominal impedance of 37Ω (three-quarter drive strength) at $V_{DDQ}/2$.
 2. The full variation in drive current, from minimum to maximum—due to process, voltage, and temperature—will lie within the outer bounding lines of the I-V curves.
 3. Contact factory for availability of three-quarter drive strength.

Table 13: Target Output Drive Characteristics (One-Half Strength)

Notes 1–2 apply to all values. Characteristics are specified under best and worst process variations/conditions

Voltage (V)	Pull-Down Current (mA)		Pull-Up Current (mA)	
	Min	Max	Min	Max
0.00	0.00	0.00	0.00	0.00
0.10	1.27	8.42	-1.27	-8.42
0.20	2.55	12.30	-2.55	-12.30
0.30	3.82	14.95	-3.82	-14.95
0.40	5.09	16.84	-5.09	-16.84
0.50	6.36	18.20	-6.36	-18.20
0.60	7.64	19.30	-7.64	-19.30
0.70	8.91	20.30	-8.91	-20.30
0.80	10.16	21.20	-10.16	-21.20
0.85	10.80	21.60	-10.80	-21.60
0.90	10.80	22.00	-10.80	-22.00
0.95	10.80	22.45	-10.80	-22.45
1.00	10.80	22.73	-10.80	-22.73
1.10	10.80	23.21	-10.80	-23.21
1.20	10.80	23.67	-10.80	-23.67
1.30	10.80	24.14	-10.80	-24.14
1.40	10.80	24.61	-10.80	-24.61
1.50	10.80	25.08	-10.80	-25.08
1.60	10.80	25.54	-10.80	-25.54
1.70	10.80	26.01	-10.80	-26.01
1.80	-	26.48	-	-26.48
1.90	-	26.95	-	-26.95

- Notes:
1. Table values based on nominal impedance of 55Ω (half-drive) at $V_{DDQ}/2$.
 2. The full variation in drive current, from minimum to maximum—due to process, voltage, and temperature—will lie within the outer bounding lines of the I-V curves.
 3. The I-V curve for one-quarter drive strength is approximately 50 percent of one-half drive strength.

Functional Description

The Mobile DDR SDRAM uses a double data rate architecture to achieve high-speed operation. The double data rate architecture is essentially a $2n$ -prefetch architecture, with an interface designed to transfer two data words per clock cycle at the I/O. Single read or write access for Mobile DDR SDRAM consists of a single $2n$ -bit-wide, one-clock-cycle data transfer at the internal DRAM core and two corresponding n -bit-wide, one-half-clock-cycle data transfers at the I/O.

A bidirectional data strobe (DQS) is transmitted externally, along with data, for use in data capture at the receiver. DQS is a strobe transmitted by the Mobile DDR SDRAM during READs and by the memory controller during WRITES. DQS is edge-aligned with data for READs and center-aligned with data for WRITES. The x16 device has two data strobes, one for the lower byte and one for the upper byte; the x32 device has four data strobes, one per byte.

The Mobile DDR SDRAM operates from a differential clock (CK and CK#); the crossing of CK going HIGH and CK# going LOW will be referred to as the positive edge of CK. Commands (address and control signals) are registered at every positive edge of CK. Input data is registered on both edges of DQS, and output data is referenced to both edges of DQS, as well as to both edges of CK.

Read and write accesses to the Mobile DDR SDRAM are burst oriented; accesses start at a selected location and continue for a programmed number of locations in a programmed sequence. Accesses begin with the registration of an ACTIVE command, which is then followed by a READ or WRITE command. The address bits registered coincident with the ACTIVE command are used to select the bank and row to be accessed. The address bits registered coincident with the READ or WRITE command are used to select the starting column location for the burst access.

The Mobile DDR SDRAM provides for programmable READ or WRITE burst lengths of 2, 4, 8, or 16. An auto precharge function may be enabled to provide a self-timed row precharge that is initiated at the end of the burst access.

As with standard DDR SDRAMs, the pipelined, multibank architecture of Mobile DDR SDRAMs supports concurrent operation, thereby providing high effective bandwidth by hiding row precharge and activation time.

An auto refresh mode is provided, along with a power saving power-down mode. Deep power-down mode is offered to achieve maximum power reduction by eliminating the power of the memory array. Data will not be retained after the device enters deep power-down mode.

Two self refresh features, temperature-compensated self refresh (TCSR) and partial-array self refresh (PASR), offer additional power savings. TCSR is controlled by the automatic on-chip temperature sensor. The PASR can be customized using the extended mode register settings. The two features may be combined to achieve even greater power savings.

The DLL that is typically used on standard DDR devices is not necessary on the Mobile DDR SDRAM. It has been omitted to save power.

Commands

Table 14 and Table 15 provide a quick reference of available commands. This is followed by a written description of each command. Three additional truth tables (Table 16 on page 36, Table 17 on page 37, and Table 18 on page 39) provide CKE commands and current/next state information.

Table 14: Truth Table – Commands

CKE is HIGH for all commands shown except SELF REFRESH and DEEP POWER-DOWN; all states and sequences not shown are reserved and/or illegal

Name (Function)	CS#	RAS#	CAS#	WE#	Address	Notes
DESELECT (NOP)	H	X	X	X	X	1
NO OPERATION (NOP)	L	H	H	H	X	1
ACTIVE (select bank and activate row)	L	L	H	H	Bank/row	2
READ (select bank and column, and start READ burst)	L	H	L	H	Bank/column	3
WRITE (select bank and column, and start WRITE burst)	L	H	L	L	Bank/column	3
BURST TERMINATE or DEEP POWER-DOWN (enter deep power-down mode)	L	H	H	L	X	4, 5
PRECHARGE (deactivate row in bank or banks)	L	L	H	L	Code	6
AUTO REFRESH (refresh all or single bank) or SELF REFRESH (enter self refresh mode)	L	L	L	H	X	7, 8
LOAD MODE REGISTER	L	L	L	L	Op-code	9

- Notes:
1. Deselect and NOP are functionally interchangeable.
 2. BA0–BA1 provide bank address and A[0:i] provide row address (where *i* = the most significant address bit for each configuration).
 3. BA0–BA1 provide bank address; A[0:i] provide column address (where *i* = the most significant address bit for each configuration); A10 HIGH enables the auto precharge feature (nonpersistent); A10 LOW disables the auto precharge feature.
 4. Applies only to READ bursts with auto precharge disabled; this command is undefined and should not be used for READ bursts with auto precharge enabled and for WRITE bursts.
 5. This command is a BURST TERMINATE if CKE is HIGH and DEEP POWER-DOWN if CKE is LOW.
 6. A10 LOW: BA0–BA1 determine which bank is precharged.
A10 HIGH: all banks are precharged and BA0–BA1 are “Don’t Care.”
 7. This command is AUTO REFRESH if CKE is HIGH, SELF REFRESH if CKE is LOW.
 8. Internal refresh counter controls row addressing; in self refresh mode all inputs and I/Os are “Don’t Care” except for CKE.
 9. BA0–BA1 select the standard mode register, extended mode register, or status register.

Table 15: DM Operation Truth Table

Name (Function)	DM	DQ	Notes
Write enable	L	Valid	1, 2
Write inhibit	H	X	1, 2

- Notes:
1. Used to mask write data; provided coincident with the corresponding data.
 2. All states and sequences not shown are reserved and/or illegal.

DESELECT

The Deselect function (CS# HIGH) prevents new commands from being executed by the Mobile DDR SDRAM. Operations already in progress are not affected.

NO OPERATION (NOP)

The NO OPERATION (NOP) command is used to instruct the selected Mobile DDR SDRAM to perform a NOP. This prevents unwanted commands from being registered during idle or wait states. Operations already in progress are not affected.

LOAD MODE REGISTER

The mode registers are loaded via inputs A[0:n]. See mode register descriptions in “Register Definition” on page 43. The LOAD MODE REGISTER command can only be issued when all banks are idle, and a subsequent executable command cannot be issued until t_{MRD} is met.

ACTIVE

The ACTIVE command is used to open (or activate) a row in a particular bank for a subsequent access. The values on the BA0 and BA1 inputs select the bank, and the address provided on inputs A[0:n] selects the row. This row remains active (or open) for accesses until a PRECHARGE command is issued to that bank. A PRECHARGE command must be issued before opening a different row in the same bank.

Figure 9: ACTIVE Command

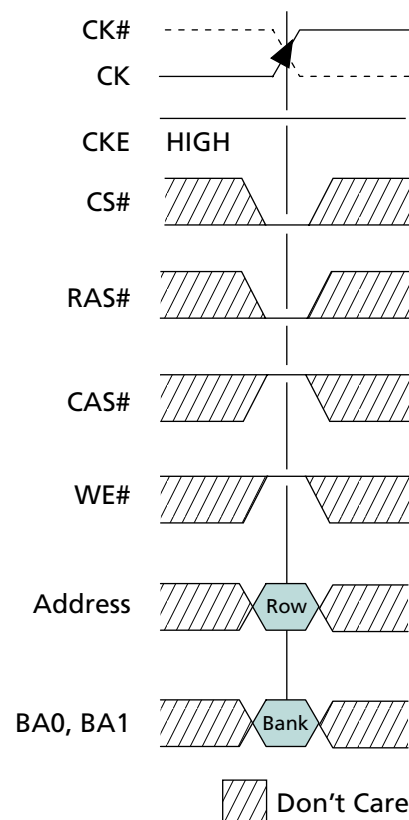

READ

The READ command is used to initiate a burst read access to an active row. The values on the BA0 and BA1 inputs select the bank; the address provided on inputs A[0:A i] (where i = the most significant column address bit for each configuration) selects the starting column location. The value on input A10 determines whether auto precharge is used. If auto precharge is selected, the row being accessed will be precharged at the end of the READ burst; if auto precharge is not selected, the row will remain open for subsequent accesses.

Figure 10: READ Command

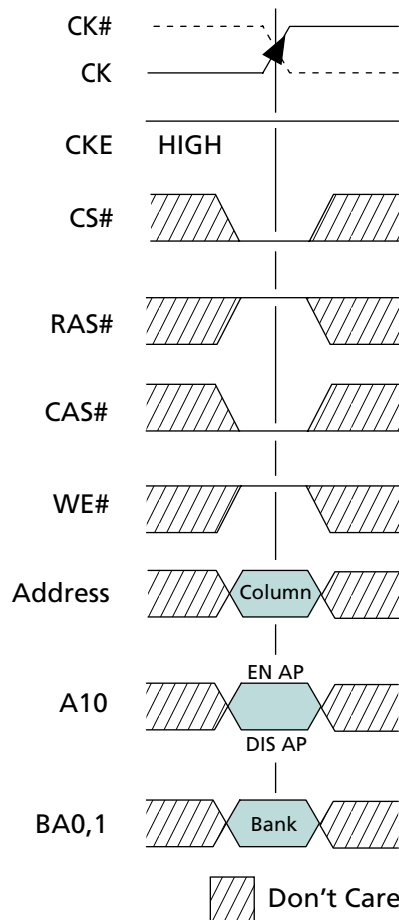

Notes: 1. EN AP = enable auto precharge; DIS AP = disable auto precharge.

WRITE

The WRITE command is used to initiate a burst write access to an active row. The values on the BA0 and BA1 inputs select the bank; the address provided on inputs A[0: i] (where i = the most significant column address bit for each configuration) selects the starting column location. The value on input A10 determines whether auto precharge is used. If auto precharge is selected, the row being accessed will be precharged at the end of the WRITE burst; if auto precharge is not selected, the row will remain open for subsequent accesses. Input data appearing on the DQs is written to the memory array subject to the

DM input logic level appearing coincident with the data. If a given DM signal is registered LOW, the corresponding data will be written to memory; if the DM signal is registered HIGH, the corresponding data inputs will be ignored, and a WRITE will not be executed to that byte/column location.

If a WRITE or a READ is in progress, the entire data burst must be complete prior to stopping the clock (see the “Stopping the External Clock” section on page 83). A burst completion for WRITES is defined when the write postamble and t^{WR} or t^{WTR} are satisfied.

Figure 11: WRITE Command

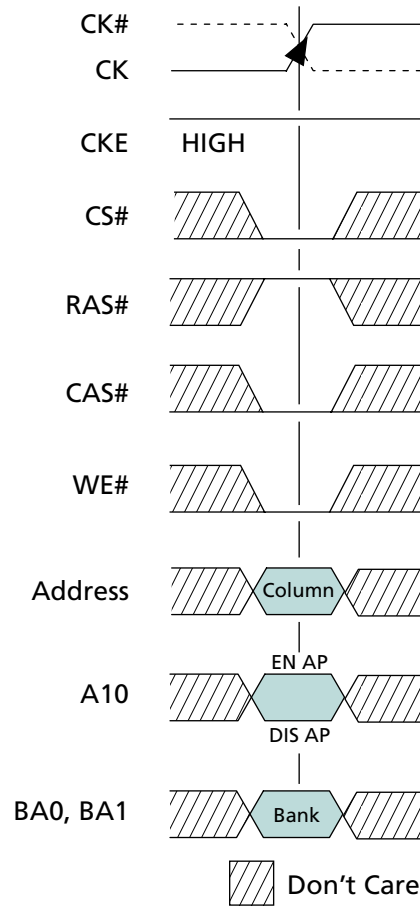

Notes: 1. EN AP = enable auto precharge; DIS AP = disable auto precharge.

PRECHARGE

The PRECHARGE command is used to deactivate the open row in a particular bank or the open row in all banks. The bank(s) will be available for a subsequent row access a specified time (t_{RP}) after the PRECHARGE command is issued. Input A10 determines whether one or all banks are to be precharged, and in the case where only one bank is to be precharged, inputs BA0 and BA1 select the bank. Otherwise, BA0 and BA1 are treated as “Don’t Care.” After a bank has been precharged, it is in the idle state and must be activated prior to any READ or WRITE commands being issued to that bank.

Figure 12: PRECHARGE Command

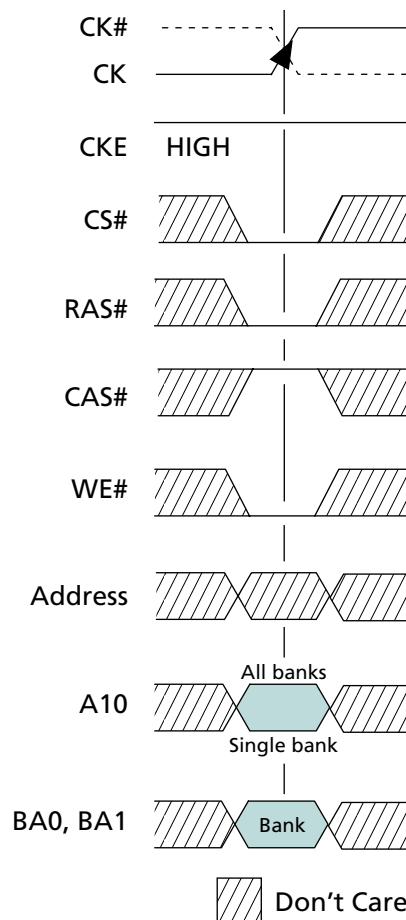

Notes: 1. If A10 is HIGH, bank address becomes “Don’t Care.”

BURST TERMINATE

The BURST TERMINATE command is used to truncate READ bursts with auto precharge disabled. The most recently registered READ command prior to the BURST TERMINATE command will be truncated, as described in “READS” on page 51. The open page from which the READ was terminated remains open.

AUTO REFRESH

AUTO REFRESH is used during normal operation of the Mobile DDR SDRAM and is analogous to CAS#-BEFORE-RAS# (CBR) REFRESH in FPM/EDO DRAMs. The AUTO REFRESH command is nonpersistent and must be issued each time a refresh is required.

The addressing is generated by the internal refresh controller. This makes the address bits a “Don’t Care” during an AUTO REFRESH command.

To provide improved efficiency in scheduling and switching between tasks, some flexibility in the absolute refresh interval is provided. The auto refresh period begins when the AUTO REFRESH command is registered and ends t_{RFC} later.

SELF REFRESH

The SELF REFRESH command can be used to retain data in the Mobile DDR SDRAM, even if the rest of the system is powered down. When in the self refresh mode, the Mobile DDR SDRAM retains data without external clocking. The SELF REFRESH command is initiated like an AUTO REFRESH command, except that CKE is disabled (LOW). All command and address input signals except CKE are “Don’t Care” during SELF REFRESH. See Figure 48 on page 80 for details on entering and exiting self refresh mode.

During SELF REFRESH, the device is refreshed as identified in the extended mode register (see “Partial-Array Self Refresh (PASR)” on page 47). An internal temperature sensor will adjust the refresh rate to optimize device power consumption while ensuring data integrity (see “Temperature-Compensated Self Refresh (TCSR)” on page 47).

The procedure for exiting SELF REFRESH requires a sequence of commands. First, CK must be stable prior to CKE going back HIGH. When CKE is HIGH, the Mobile DDR SDRAM must have NOP commands issued for t_{XSR} time.

During SELF REFRESH operation, refresh intervals are scheduled internally and may vary. These refresh intervals may be different than the specified t_{REFI} time. For this reason, the SELF REFRESH command must not be used as a substitute for the AUTO REFRESH command.

DEEP POWER-DOWN

The DEEP POWER-DOWN (DPD) command is used to enter DPD operating mode, which achieves maximum power reduction by eliminating the power of the memory array. Data will not be retained when the device enters DPD mode. The DPD command is the same as a BURST TERMINATE command with CKE LOW.

Figure 13: DEEP POWER-DOWN Command

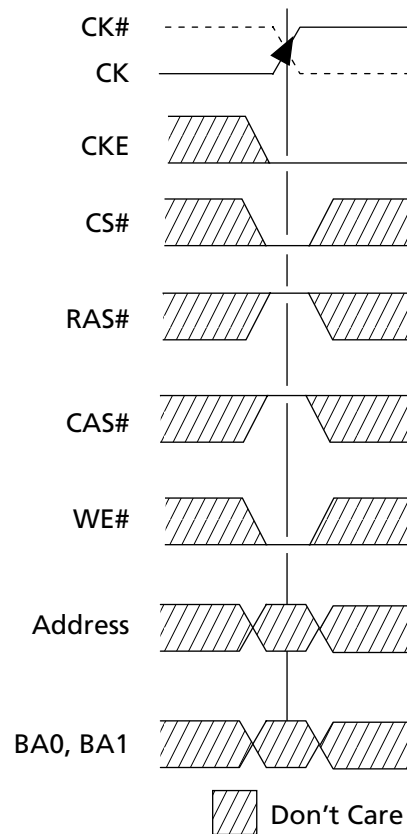

Operations

Table 16: Truth Table – Current State Bank n – Command to Bank n

Notes: 1–6; notes appear below and on next page

Current State	CS#	RAS#	CAS#	WE#	Command/Action	Notes
Any	H	X	X	X	DESELECT (NOP/continue previous operation)	
	L	H	H	H	NO OPERATION (NOP/continue previous operation)	
Idle	L	L	H	H	ACTIVE (select and activate row)	
	L	L	L	H	AUTO REFRESH	7
	L	L	L	L	LOAD MODE REGISTER	7
Row active	L	H	L	H	READ (select column and start READ burst)	10
	L	H	L	L	WRITE (select column and start WRITE burst)	10
	L	L	H	L	PRECHARGE (deactivate row in bank or banks)	8
Read (auto precharge disabled)	L	H	L	H	READ (select column and start new READ burst)	10
	L	H	L	L	WRITE (select column and start WRITE burst)	10, 12
	L	L	H	L	PRECHARGE (truncate READ burst, start PRECHARGE)	8
	L	H	H	L	BURST TERMINATE	9
Write (auto precharge disabled)	L	H	L	H	READ (select column and start READ burst)	10, 11
	L	H	L	L	WRITE (select column and start new WRITE burst)	10
	L	L	H	L	PRECHARGE (truncate WRITE burst, start PRECHARGE)	8, 11

- Notes:
- This table applies when CKE_{n-1} was HIGH and CKE_n is HIGH and after t^{XSR} has been met (if the previous state was self refresh), after t^{XP} has been met (if the previous state was power-down, or a full initialization if the previous state was deep power-down).
 - This table is bank-specific, except where noted (for example, the current state is for a specific bank and the commands shown are those supported for that bank when in that state). Exceptions are covered in the notes below.
 - Current state definitions:
 - Idle: The bank has been precharged, and t^{RP} has been met.
 - Row active: A row in the bank has been activated, and t^{RCD} has been met. No data bursts/accesses and no register accesses are in progress.
 - Read: A READ burst has been initiated with auto precharge disabled and has not yet terminated or been terminated.
 - Write: A WRITE burst has been initiated with auto precharge disabled and has not yet terminated or been terminated.
 - The following states must not be interrupted by a command issued to the same bank. COMMAND INHIBIT or NOP commands, or supported commands to the other bank, should be issued on any clock edge occurring during these states. Supported commands to any other bank are determined by that bank's current state.
 - Precharging: Starts with registration of a PRECHARGE command and ends when t^{RP} is met. After t^{RP} is met, the bank will be in the idle state.
 - Row activating: Starts with registration of an ACTIVE command and ends when t^{RCD} is met. After t^{RCD} is met, the bank will be in the row active state.
 - Read w/auto-precharge enabled: Starts with registration of a READ command with auto precharge enabled and ends when t^{RP} has been met. After t^{RP} is met, the bank will be in the idle state.
 - Write w/auto-precharge enabled: Starts with registration of a WRITE command with auto precharge enabled and ends when t^{RP} has been met. After t^{RP} is met, the bank will be in the idle state.

5. The following states must not be interrupted by any executable command; DESELECT or NOP commands must be applied on each positive clock edge during these states.
 - Refreshing: Starts with registration of an AUTO REFRESH command and ends when t^1_{RFC} is met. After t^1_{RFC} is met, the DDR SDRAM will be in the all banks idle state.
 - Accessing mode register: Starts with registration of a LOAD MODE REGISTER command and ends when t^1_{MRD} has been met. After t^1_{MRD} is met, the Mobile DDR SDRAM will be in the all banks idle state.
 - Precharging all: Starts with registration of a PRECHARGE ALL command and ends when t^1_{RP} is met. After t^1_{RP} is met, all banks will be in the idle state.
6. All states and sequences not shown are illegal or reserved.
7. Not bank-specific; requires that all banks are idle, and bursts are not in progress.
8. May or may not be bank-specific; if multiple banks are to be precharged, each must be in a valid state for precharging.
9. Not bank-specific; BURST TERMINATE affects the most recent READ burst, regardless of bank.
10. READs or WRITEs listed in the Command/Action column include READs or WRITEs with auto precharge enabled and READs or WRITEs with auto precharge disabled.
11. Requires appropriate DM masking.
12. A WRITE command may be applied after the completion of the READ burst; otherwise, a BURST TERMINATE must be used to end the READ burst prior to asserting a WRITE command.

Table 17: Truth Table – Current State Bank n – Command to Bank m

Notes: 1–5; notes appear below and on next page

Current State	CS#	RAS#	CAS#	WE#	Command/Action	Notes
Any	H	X	X	X	DESELECT (NOP/continue previous operation)	
	L	H	H	H	NO OPERATION (NOP/continue previous operation)	
Idle	X	X	X	X	Any command supported to bank m	
Row activating, active, or precharging	L	L	H	H	ACTIVE (select and activate row)	
	L	H	L	H	READ (select column and start READ burst)	5
	L	H	L	L	WRITE (select column and start WRITE burst)	5
	L	L	H	L	PRECHARGE	
Read (auto precharge disabled)	L	L	H	H	ACTIVE (select and activate row)	
	L	H	L	H	READ (select column and start new READ burst)	5
	L	H	L	L	WRITE (select column and start WRITE burst)	5, 7
	L	L	H	L	PRECHARGE	
Write (auto precharge disabled)	L	L	H	H	ACTIVE (select and activate row)	
	L	H	L	H	READ (select column and start READ burst)	5, 6
	L	H	L	L	WRITE (select column and start new WRITE burst)	5
	L	L	H	L	PRECHARGE	
Read (with auto precharge)	L	L	H	H	ACTIVE (select and activate row)	
	L	H	L	H	READ (select column and start new READ burst)	5, 3a
	L	H	L	L	WRITE (select column and start WRITE burst)	5, 7, 3a
	L	L	H	L	PRECHARGE	
Write (with auto precharge)	L	L	H	H	ACTIVE (select and activate row)	
	L	H	L	H	READ (select column and start READ burst)	5, 3a
	L	H	L	L	WRITE (select column and start new WRITE burst)	5, 3a
	L	L	H	L	PRECHARGE	

- Notes:
1. This table applies when CKE_{n-1} was HIGH and CKE_n is HIGH and after t^1XSR has been met (if the previous state was self refresh), after t^1XP has been met (if the previous state was power-down, or a full initialization if the previous state was deep power-down).
 2. This table describes alternate bank operation, except where noted (for example, the current state is for bank n and the commands shown are those supported for issue to bank m , assuming that bank m is in such a state that the given command is supported). Exceptions are covered in the notes below.
 3. Current state definitions:

Idle: The bank has been precharged, and t^1RP has been met.
 Row active: A row in the bank has been activated, and t^1RCD has been met. No data bursts/accesses and no register accesses are in progress.
 Read: A READ burst has been initiated and has not yet terminated or been terminated.
 Write: A WRITE burst has been initiated and has not yet terminated or been terminated.

- 3a. The read with auto precharge enabled or write with auto precharge enabled states can each be broken into two parts: the access period and the precharge period. For read with auto precharge, the precharge period is defined as if the same burst was executed with auto precharge disabled and then followed with the earliest possible PRECHARGE command that still accesses all of the data in the burst. For write with auto precharge, the precharge period begins when t^1WR ends, with t^1WR measured as if auto precharge was disabled. The access period starts with registration of the command and ends where the precharge period (or t^1RP) begins.

This device supports concurrent auto precharge such that when a read with auto precharge is enabled or a write with auto precharge is enabled, any command to other banks is supported, as long as that command does not interrupt the read or write data transfer already in process. In either case, all other related limitations apply (for example, contention between read data and write data must be avoided).

- 3b. The minimum delay from a READ or WRITE command with auto precharge enabled to a command to a different bank is summarized below.

From Command	To Command	Minimum Delay (with Concurrent Auto Precharge)
WRITE w/AP	READ or READ w/AP WRITE or WRITE w/AP PRECHARGE ACTIVE	$[1 + (BL/2)] t^1CK + t^1WTR$ $(BL/2) t^1CK$ $1 t^1CK$ $1 t^1CK$
READ w/AP	READ or READ w/AP WRITE or WRITE w/AP PRECHARGE ACTIVE	$(BL/2) \times t^1CK$ $[CL + (BL/2)] t^1CK$ $1 t^1CK$ $1 t^1CK$

4. AUTO REFRESH and LOAD MODE REGISTER commands may only be issued when all banks are idle.
5. All states and sequences not shown are illegal or reserved.
6. Requires appropriate DM masking.
7. A WRITE command may be applied after the completion of the READ burst; otherwise, a BURST TERMINATE must be used to end the READ burst prior to asserting a WRITE command.

Table 18: Truth Table – CKE

Notes: 1–4

CKE_{n-1}	CKE_n	Current State	$COMMAND_n$	$ACTION_n$	Notes
L	L	Active power-down	X	Maintain active power-down	
L	L	Deep power-down	X	Maintain deep power-down	
L	L	(Precharge) power-down	X	Maintain (precharge) power-down	
L	L	Self refresh	X	Maintain self refresh	
L	H	Active power-down	DESELECT or NOP	Exit active power-down	5
L	H	Deep power-down	DESELECT or NOP	Exit deep power-down	6
L	H	(Precharge) power-down	DESELECT or NOP	Exit (precharge) power-down	
L	H	Self refresh	DESELECT or NOP	Exit self refresh	5, 7
H	L	Bank(s) active	DESELECT or NOP	Active power-down entry	
H	L	All banks idle	BURST TERMINATE	Deep power-down entry	
H	L	All banks idle	DESELECT or NOP	(Precharge) power-down entry	
H	L	All banks idle	AUTO REFRESH	Self refresh entry	
H	H		See Table 17 on page 37		
H	H		See Table 17 on page 37		

- Notes:
1. CKE_n is the logic state of CKE at clock edge n ; CKE_{n-1} was the state of CKE at the previous clock edge.
 2. Current state is the state of the DDR SDRAM immediately prior to clock edge n .
 3. $COMMAND_n$ is the command registered at clock edge n , and $ACTION_n$ is a result of $COMMAND_n$.
 4. All states and sequences not shown are illegal or reserved.
 5. DESELECT or NOP commands should be issued on any clock edges occurring during the t_{XP} or t_{XSR} period.
 6. Upon exiting deep power-down mode, a full DRAM initialization sequence is required.
 7. The clock must toggle at least two times during the t_{XSR} period.

Figure 14: Mobile DRAM Simplified State Diagram

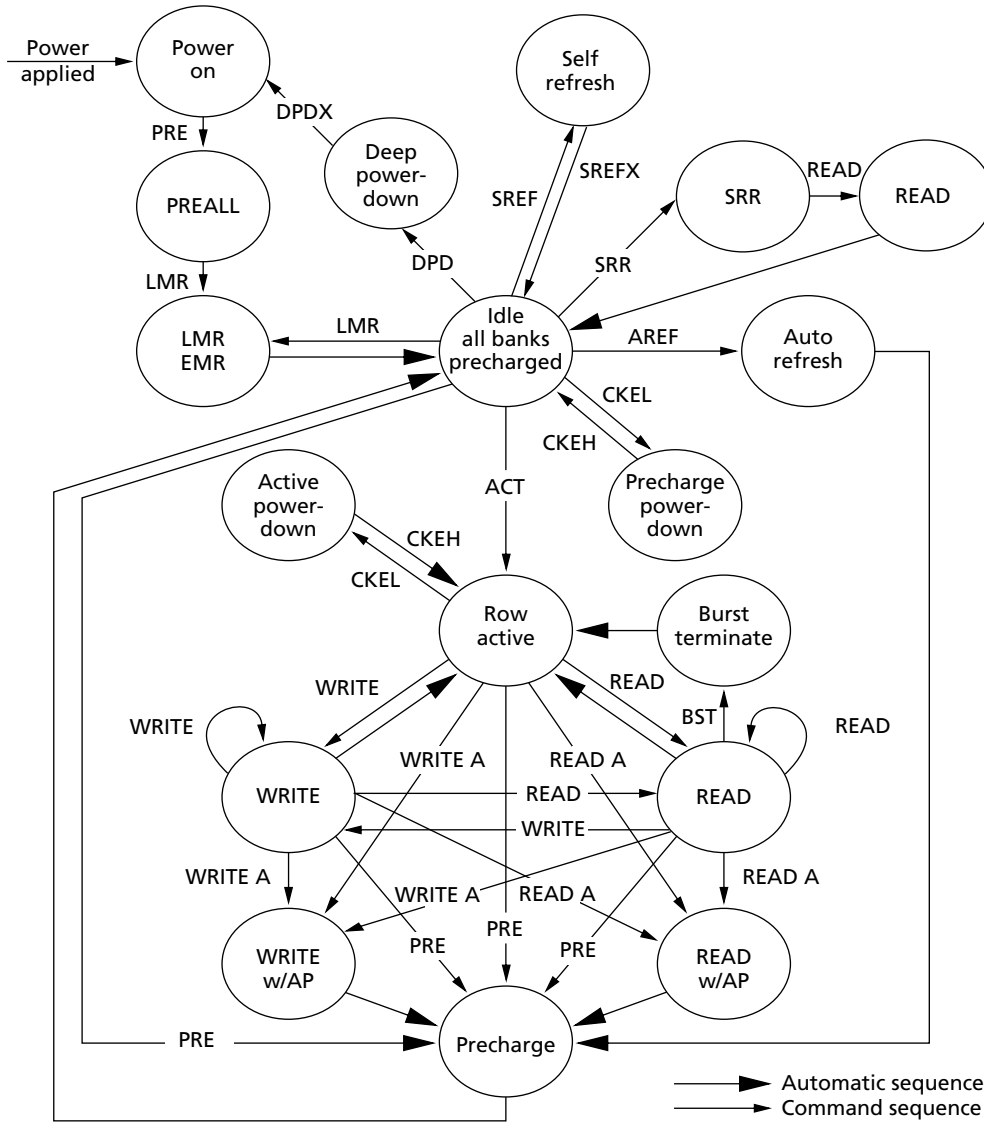

ACT = ACTIVE
 AREF = AUTO REFRESH
 BST = BURST TERMINATE
 CKEH = Exit power-down
 CKEL = Enter power-down
 DPD = Enter deep power-down

DPDX = Exit deep power-down
 EMR = LOAD EXTENDED MODE REGISTER
 LMR = LOAD MODE REGISTER
 PRE = PRECHARGE
 PREALL = PRECHARGE all banks
 READ = READ w/o auto precharge

READ A = READ w/ auto precharge
 SREF = Enter self refresh
 SREFX = Exit self refresh
 SRR = STATUS REGISTER READ
 WRITE = WRITE w/o auto precharge
 WRITE A = WRITE w/ auto precharge

Initialization

The following sections provide detailed information covering device initialization, register definition, and device operation.

Prior to normal operation, Mobile DDR SDRAMs must be powered up and initialized in a predefined manner. Initialization procedures, other than those specified, will result in undefined operation.

If there is an interruption to the device power, the initialization routine must be followed to ensure proper functionality of the Mobile DDR SDRAM.

To properly initialize the Mobile DDR SDRAM, this sequence must be followed:

1. The core power (VDD) and I/O power (VDDQ) must be brought up simultaneously. It is recommended that VDD and VDDQ be from the same power source or VDDQ must never exceed VDD. Assert and hold CKE HIGH.
2. When power supply voltages are stable and the CKE has been driven HIGH, it is safe to apply the clock.
3. When the clock is stable, a 200 μ s minimum delay is required by the Mobile DDR SDRAM prior to applying an executable command. During this time, NOP or DESELECT commands must be issued on the command bus.
4. Issue a PRECHARGE ALL command.
5. Issue NOP or DESELECT commands for at least t_{RP} time.
6. Issue an AUTO REFRESH command followed by NOP or DESELECT commands for at least t_{RFC} time. Issue a second AUTO REFRESH command followed by NOP or DESELECT commands for at least t_{RFC} time. Two AUTO REFRESH commands must be issued. Typically, both of these commands are issued at this stage as described above.
7. Using the LOAD MODE REGISTER command, load the standard mode register as desired.
8. Issue NOP or DESELECT commands for at least t_{MRD} time.
9. Using the LOAD MODE REGISTER command, load the extended mode register to the desired operating modes. Note that the sequence in which the standard and extended mode registers are programmed is not critical.
10. Issue NOP or DESELECT commands for at least t_{MRD} time.

After steps 1 through 10 are completed, the Mobile DDR SDRAM has been properly initialized and is ready to receive any valid command.

Figure 15: Initialize and Load Mode Registers

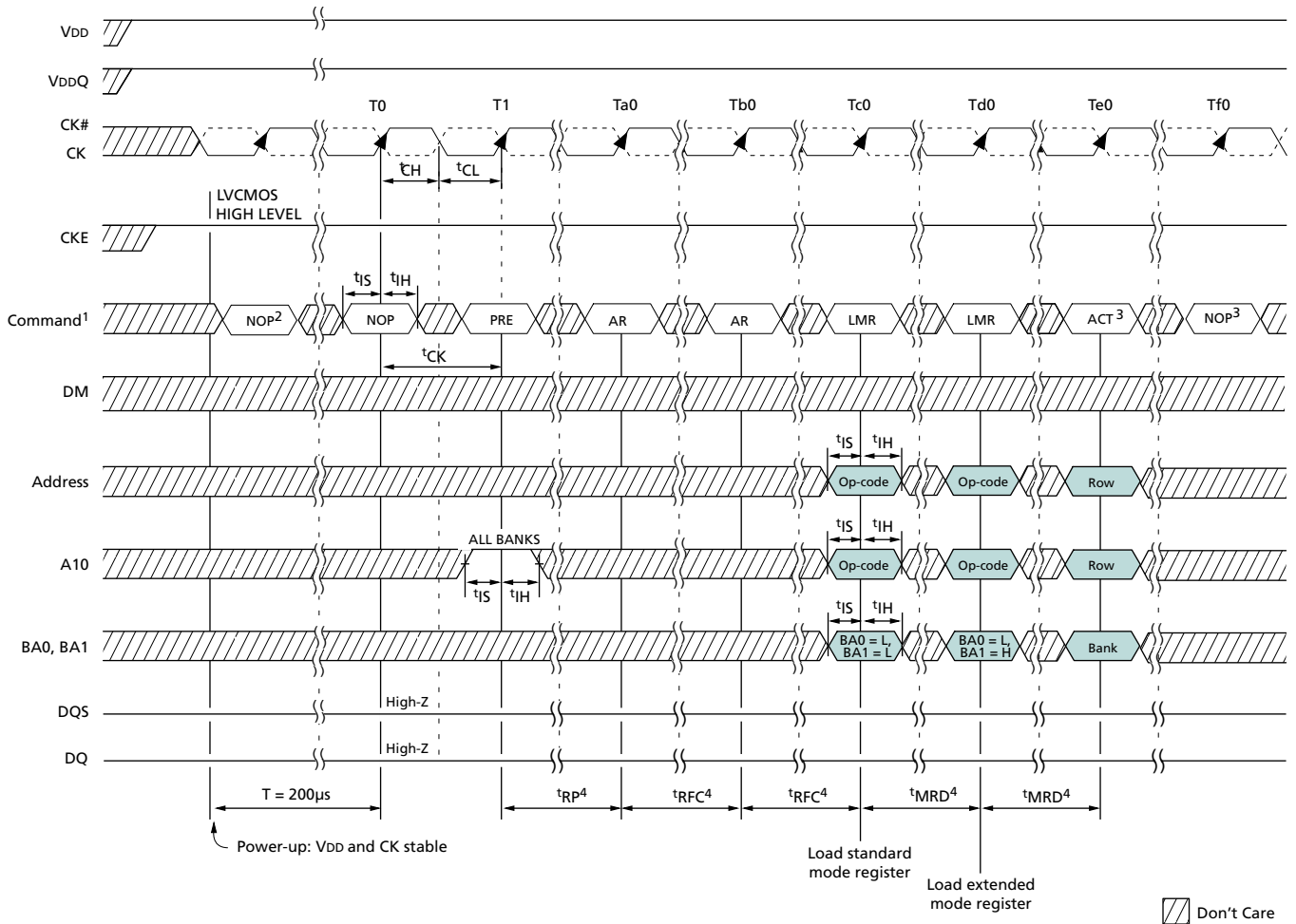

- Notes:
1. PRE = PRECHARGE command; LMR = LOAD MODE REGISTER command; AR = AUTO REFRESH command; ACT = ACTIVE command
 2. NOP or DESELECT commands are required for at least 200 μ s.
 3. Other valid commands are possible.
 4. NOPs or DESELECTs are required during this time.

Register Definition

Mode Registers

The mode registers are used to define the specific mode of operation of the Mobile DDR SDRAM. Two mode registers are used to specify the operational characteristics of the device: standard mode register and extended mode register.

Standard Mode Register

The standard mode register bit definition enables the selection of burst length, burst type, CAS latency, and operating mode, as shown in Figure 16 on page 43. Reserved states should not be used as it may result in setting the device into an unknown state or cause incompatibility with future versions of Mobile DDR SDRAMs. The standard mode register is programmed via the LOAD MODE REGISTER command (with BA0 = 0 and BA1 = 0) and will retain the stored information until it is programmed again, the device goes into deep power-down mode, or the device loses power.

Reprogramming the mode register will not alter the contents of the memory, provided it is performed correctly. The mode register must be loaded when all banks are idle and no bursts are in progress, and the controller must wait t_{MRD} before initiating the subsequent operation. Violating any of these requirements will result in unspecified operation.

Figure 16: Standard Mode Register Definition

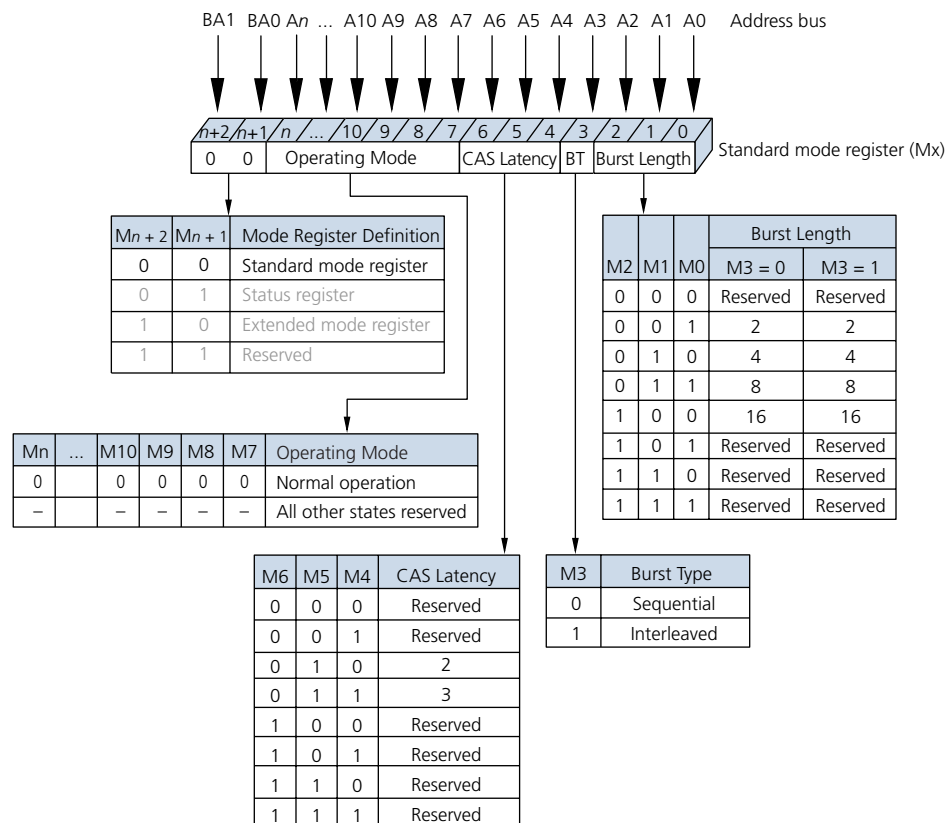

Notes: 1. The integer n is equal to the most significant address bit.

Burst Length (BL)

Read and write accesses to the Mobile DDR SDRAM are burst oriented, with the burst length (BL) being programmable. The BL determines the maximum number of column locations that can be accessed for a given READ or WRITE command. Burst lengths of 2, 4, 8, or 16 locations are available for both sequential and interleaved burst types.

When a READ or WRITE command is issued, a block of columns equal to the BL is effectively selected. All accesses for that burst take place within this block, meaning that the burst will wrap when a boundary is reached. The block is uniquely selected by $A1-A_i$ when $BL = 2$, by $A2-A_i$ when $BL = 4$, by $A3-A_i$ when $BL = 8$, and by $A4-A_i$ when $BL = 16$, where A_i is the most significant column address bit for a given configuration. The remaining (least significant) address bits are used to specify the starting location within the block. The programmed BL applies to both READ and WRITE bursts.

Burst Type

Accesses within a given burst may be programmed to be either sequential or interleaved via the standard mode register.

The ordering of accesses within a burst is determined by the burst length, the burst type, and the starting column address. See Table 19 on page 45 for details.

Table 19: Burst Definition Table

Burst Length	Starting Column Address				Order of Accesses Within a Burst					
					Type = Sequential	Type = Interleaved				
2	A0									
					0	0-1	0-1			
					1	1-0	1-0			
4	A1			A0						
					0	0	0-1-2-3	0-1-2-3		
					0	1	1-2-3-0	1-0-3-2		
					1	0	2-3-0-1	2-3-0-1		
					1	1	3-0-1-2	3-2-1-0		
8	A2	A1	A0							
				0	0	0	0-1-2-3-4-5-6-7	0-1-2-3-4-5-6-7		
				0	0	1	1-2-3-4-5-6-7-0	1-0-3-2-5-4-7-6		
				0	1	0	2-3-4-5-6-7-0-1	2-3-0-1-6-7-4-5		
				0	1	1	3-4-5-6-7-0-1-2	3-2-1-0-7-6-5-4		
				1	0	0	4-5-6-7-0-1-2-3	4-5-6-7-0-1-2-3		
				1	0	1	5-6-7-0-1-2-3-4	5-4-7-6-1-0-3-2		
				1	1	0	6-7-0-1-2-3-4-5	6-7-4-5-2-3-0-1		
16	A3	A2	A1	A0						
					0	0	0	0	0-1-2-3-4-5-6-7-8-9-A-B-C-D-E-F	0-1-2-3-4-5-6-7-8-9-A-B-C-D-E-F
					0	0	0	1	1-2-3-4-5-6-7-8-9-A-B-C-D-E-F-0	1-0-3-2-5-4-7-6-9-8-B-A-D-C-F-E
					0	0	1	0	2-3-4-5-6-7-8-9-A-B-C-D-E-F-0-1	2-3-0-1-6-7-4-5-A-B-8-9-E-F-C-D
					0	0	1	1	3-4-5-6-7-8-9-A-B-C-D-E-F-0-1-2	3-2-1-0-7-6-5-4-B-A-9-8-F-E-D-C
					0	1	0	0	4-5-6-7-8-9-A-B-C-D-E-F-0-1-2-3	4-5-6-7-0-1-2-3-C-D-E-F-8-9-A-B
					0	1	0	1	5-6-7-8-9-A-B-C-D-E-F-0-1-2-3-4	5-4-7-6-1-0-3-2-D-C-F-E-9-8-B-A
					0	1	1	0	6-7-8-9-A-B-C-D-E-F-0-1-2-3-4-5	6-7-4-5-2-3-0-1-E-F-C-D-A-B-8-9
					0	1	1	1	7-8-9-A-B-C-D-E-F-0-1-2-3-4-5-6	7-6-5-4-3-2-1-0-F-E-D-C-B-A-9-8
					1	0	0	0	8-9-A-B-C-D-E-F-0-1-2-3-4-5-6-7	8-9-A-B-C-D-E-F-0-1-2-3-4-5-6-7
					1	0	0	1	9-A-B-C-D-E-F-0-1-2-3-4-5-6-7-8	9-8-B-A-D-C-F-E-1-0-3-2-5-4-7-6
					1	0	1	0	A-B-C-D-E-F-0-1-2-3-4-5-6-7-8-9	A-B-8-9-E-F-C-D-2-3-0-1-6-7-4-5
					1	0	1	1	B-C-D-E-F-0-1-2-3-4-5-6-7-8-9-A	B-A-9-8-F-E-D-C-3-2-1-0-7-6-5-4
					1	1	0	0	C-D-E-F-0-1-2-3-4-5-6-7-8-9-A-B	C-D-E-F-8-9-A-B-4-5-6-7-0-1-2-3
					1	1	0	1	D-E-F-0-1-2-3-4-5-6-7-8-9-A-B-C	D-C-F-E-9-8-B-A-5-4-7-6-1-0-3-2
1	1	1	0	E-F-0-1-2-3-4-5-6-7-8-9-A-B-C-D	E-F-C-D-A-B-8-9-6-7-4-5-2-3-0-1					
1	1	1	1	F-0-1-2-3-4-5-6-7-8-9-A-B-C-D-E	F-E-D-C-B-A-9-8-7-6-5-4-3-2-1-0					

CAS Latency (CL)

The CAS latency is the delay, in clock cycles, between the registration of a READ command and the availability of the first output data. The latency can be set to 2 or 3 clocks, as shown in Figure 17 on page 46.

For CL = 3, if the READ command is registered at clock edge n , then the data will be nominally available at $(n + 2 \text{ clocks} + t_{AC})$. For CL = 2, if the READ command is registered at clock edge n , then the data will be nominally available at $(n + 1 \text{ clock} + t_{AC})$.

Figure 17: CAS Latency

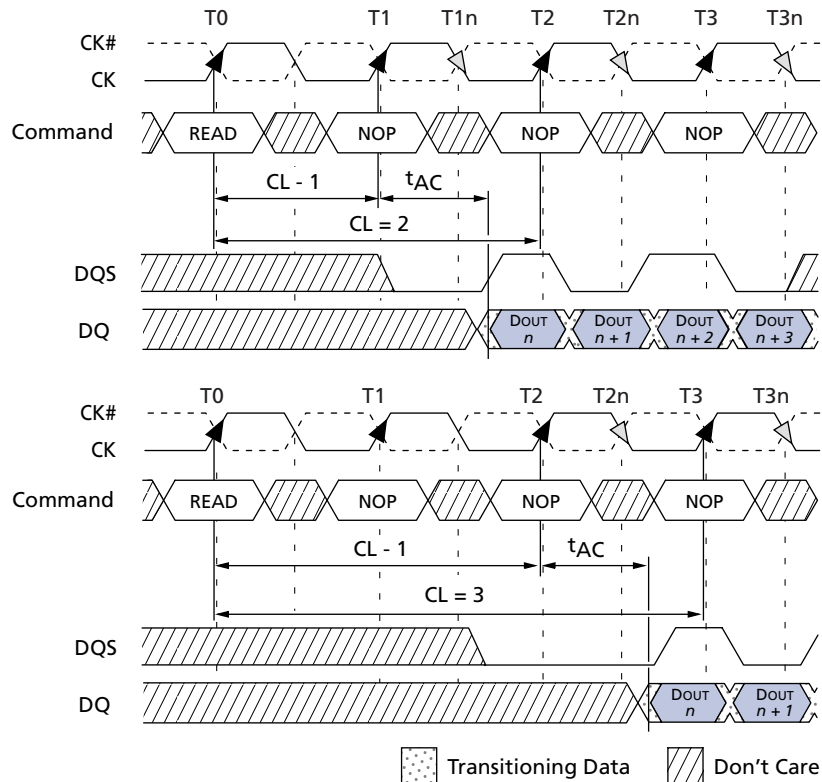

Operating Mode

The normal operating mode is selected by issuing a LOAD MODE REGISTER command with bits A[7:n] each set to zero, and bits A[6:0] set to the desired values.

All other combinations of values for A[7:n] are reserved for future use. Reserved states should not be used because unknown operation or incompatibility with future versions may result.

Extended Mode Register

The extended mode register controls additional functions beyond those set by the mode registers. These additional functions include drive strength, TCSR, and PASR.

The extended mode register is programmed via the LOAD MODE REGISTER command with BA0 = 0 and BA1 = 1. Information in the extended mode register will be retained until it is programmed again, the device goes into deep power-down mode, or the device loses power.

Temperature-Compensated Self Refresh (TCSR)

On this version of the Mobile DDR SDRAM, a temperature sensor is implemented for automatic control of the self refresh oscillator. Programming of the TCSR bits will have no effect on the device. The self refresh oscillator will continue to refresh at the factory programmed optimal rate for the device temperature.

Partial-Array Self Refresh (PASR)

For further power savings during self refresh, the PASR feature enables the controller to select the amount of memory that will be refreshed during self refresh. The refresh options are:

- Full array: banks 0, 1, 2, and 3
- Half array: banks 0 and 1
- Quarter array: bank 0
- Eighth array: bank 0 with row address most significant bit (MSB) = 0
- Sixteenth array: bank 0 with row address MSB = 0 and row address MSB - 1 = 0

WRITE and READ commands can still occur during standard operation, but only the selected regions of the array will be refreshed during self refresh. Data in regions that are not selected will be lost.

Output Drive Strength

Because the Mobile DDR SDRAM is designed for use in smaller systems that are typically point-to-point connections, an option to control the drive strength of the output buffers is provided. Drive strength should be selected based on the expected loading of the memory bus. There are four supported settings for the output drivers: 25Ω, 37Ω, 55Ω, and 80Ω internal impedance. These are full, three-quarter, one-half, and one-quarter drive strengths, respectively.

Figure 18: Extended Mode Register

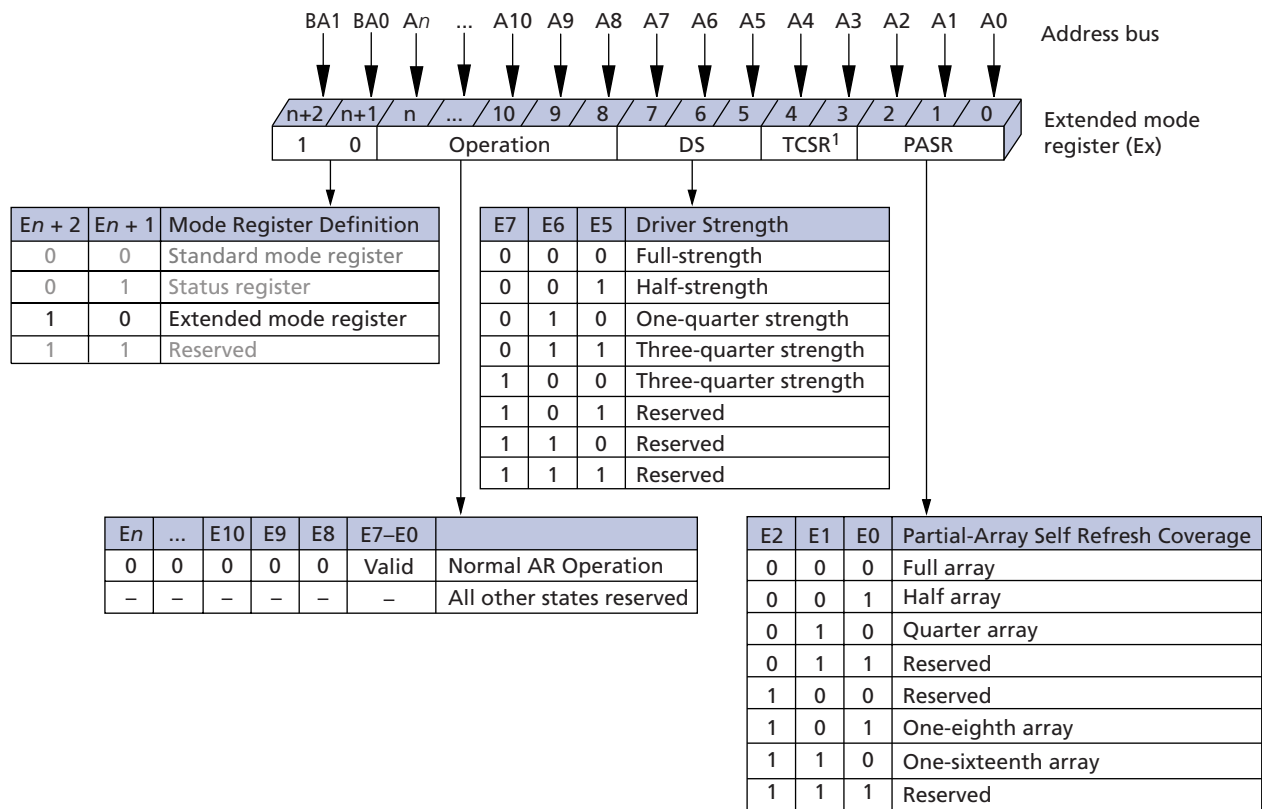

- Notes:
1. On-die temperature sensor is used in place of TCSR. Setting these bits will have no effect.
 2. The integer n is equal to the most significant address bit.

Status Read Register (SRR)

The status read register (SRR) is used to read the manufacturer ID, revision ID, refresh multiplier, width type, and density of the Mobile SDRAM, as shown in Figure 20 on page 50. The SRR is read via the LOAD MODE REGISTER command with BA0 = 1 and BA1 = 0. The sequence to perform an SRR command is as follows:

1. The SDRAM must be properly initialized and in the idle or all banks precharged state.
2. Issue a LOAD MODE REGISTER command with BA[1:0] = "01."
3. Wait t_{SRR} ; only NOP or DESELECT commands are supported during the t_{SRR} time.
4. Issue a READ command with all address pins set to "0."
5. Subsequent commands to the SDRAM must be issued t_{SRC} after the SRR READ command is issued; only NOPs or DESELECTS are supported during t_{SRC} (Figure 19 on page 49).

SRR output is read with a burst length of 2. SRR data is driven to the outputs on the first bit of the burst, with the output being "Don't Care" on the second bit of the burst.

Figure 19: SRR Timing

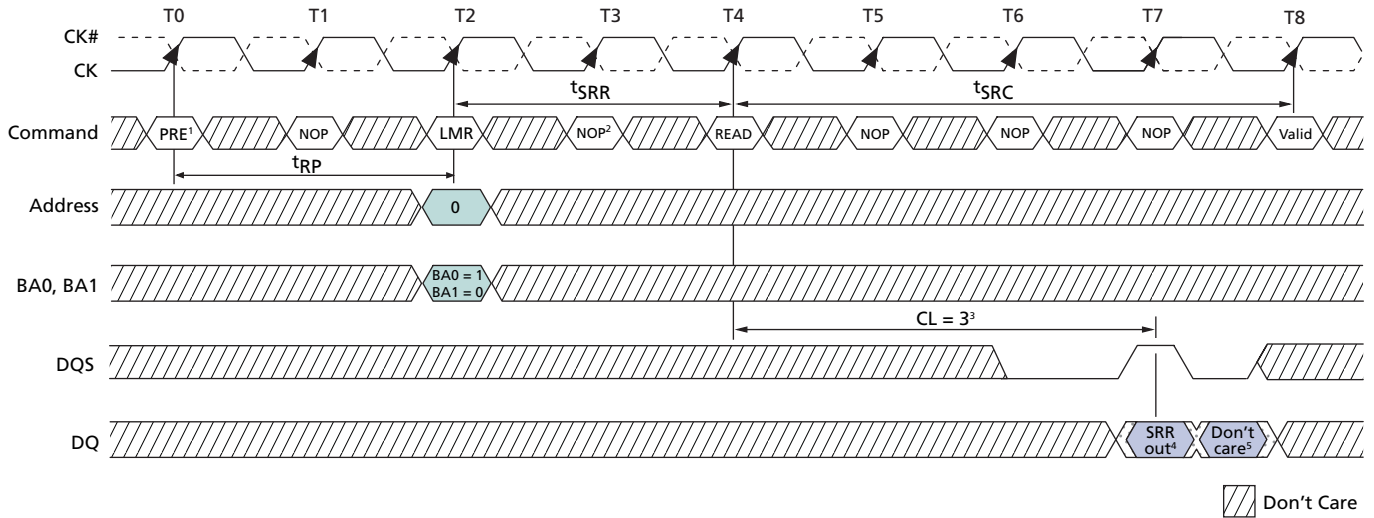

- Notes:
1. All banks must be idle prior to status register read.
 2. NOP or DESELECT commands are required between LMR and READ command (t_{SRR}) and between READ and next VALID command (t_{SRC}).
 3. CAS latency is predetermined by the programming of the mode register. CL = 3 is shown as an example only.
 4. Burst length is fixed to 2 for SRR regardless of the value programmed by the mode register.
 5. The second bit of the data-out burst is a "Don't Care."

Figure 20: Status Register Definition

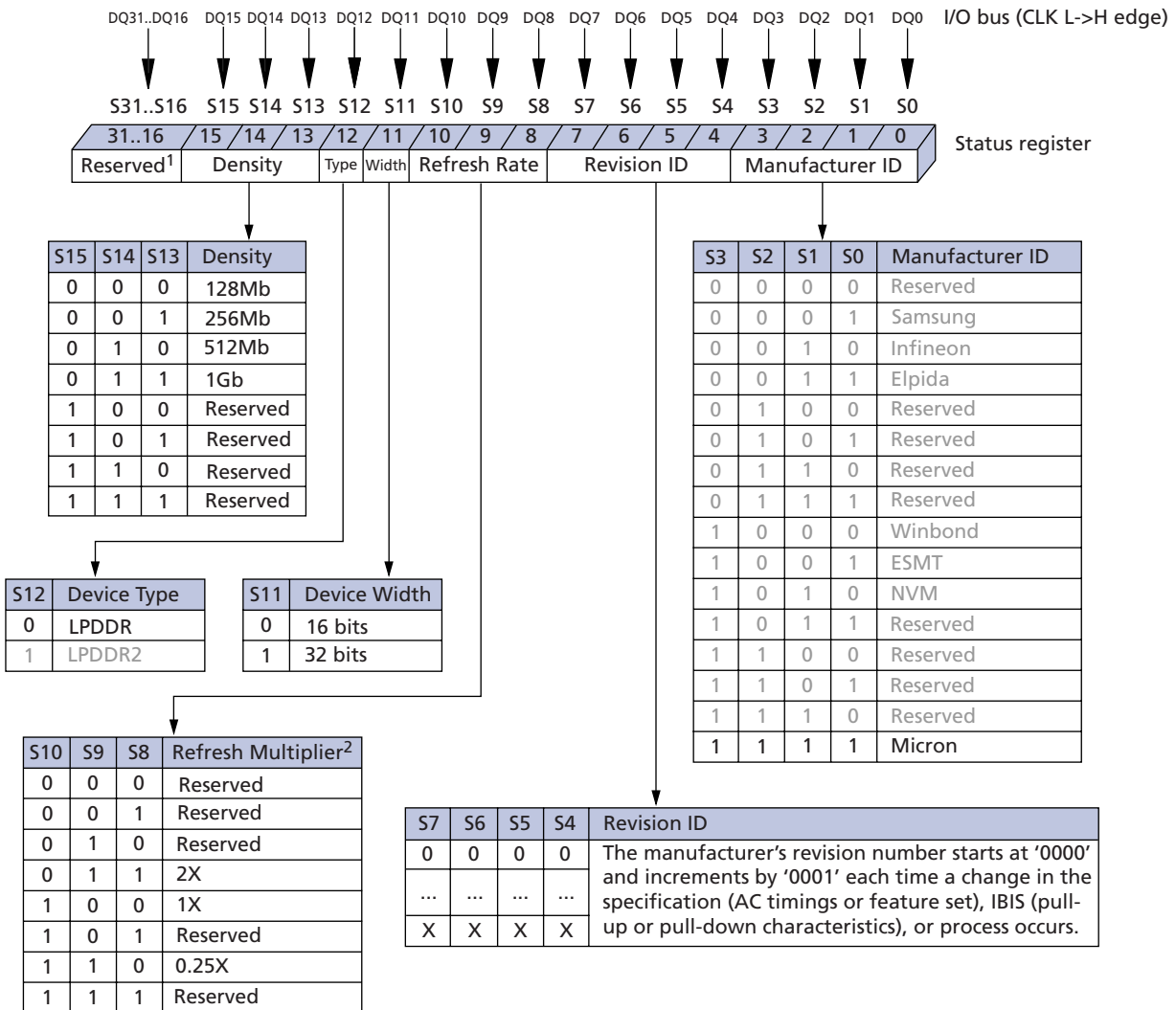

- Notes: 1. Reserved bits should be set to zero (0) for future compatibility.
 2. Refresh multiplier is based on the memory device's on-board temperature sensor. Required average periodic refresh interval = $t_{REFI} \times \text{multiplier}$.

Bank/Row Activation

Before any READ or WRITE commands can be issued to a bank within the Mobile DDR SDRAM, a row in that bank must be "opened." This is accomplished via the ACTIVE command, which selects both the bank and the row to be activated, as shown in Figure 9. After a row is opened with an ACTIVE command, a READ or WRITE command may be issued to that row, subject to the t_{RCD} specification.

A subsequent ACTIVE command to a different row in the same bank can only be issued after the previous active row has been "closed" (precharged). The minimum time interval between successive ACTIVE commands to the same bank is defined by t_{RC} .

A subsequent ACTIVE command to another bank can be issued while the first bank is being accessed, which results in a reduction of total row-access overhead. The minimum time interval between successive ACTIVE commands to different banks is defined by t_{RRD} .

Timing Diagrams

READS

READ burst operations are initiated with a READ command, as shown in Figure 10 on page 31. The starting column and bank addresses are provided with the READ command, and auto precharge is either enabled or disabled for that burst access. If auto precharge is enabled, the row being accessed is precharged at the completion of the burst. For the READ commands used in the following illustrations, auto precharge is disabled.

During READ bursts, the valid data-out element from the starting column address will be available following the CAS latency after the READ command. Each subsequent data-out element will be valid nominally at the next positive or negative clock edge. Figure 21 on page 52 shows general timing for each possible CAS latency setting. DQS is driven by the Mobile DDR SDRAM along with output data. The initial LOW state on DQS is known as the read preamble; the LOW state coincident with the last data-out element is known as the read postamble. The READ burst is considered complete when the read postamble is satisfied.

Upon completion of a burst, assuming no other commands have been initiated, the DQs will go High-Z. A detailed explanation of t_{DQSQ} (valid data-out skew), t_{QH} (data-out window hold), and the valid data window is depicted in Figure 28 on page 59 and Figure 29 on page 60. A detailed explanation of t_{DQSCK} (DQS transition skew to CK) and t_{AC} (data-out transition skew to CK) is depicted in Figure 30 on page 61.

Data from any READ burst may be truncated by a READ or WRITE command to the same or alternate bank, by a BURST TERMINATE command, or by a PRECHARGE command to the same bank, provided that the auto precharge mode was not activated.

Data from any READ burst may be concatenated with or truncated with data from a subsequent READ command. In either case, a continuous flow of data can be maintained. The first data element from the new burst either follows the last element of a completed burst or the last desired data element of a longer burst which is being truncated. The new READ command should be issued x cycles after the first READ command, where x equals the number of desired data element pairs (pairs are required by the $2n$ -prefetch architecture). This is shown in Figure 22 on page 53.

A READ command can be initiated on any clock cycle following a previous READ command. Nonconsecutive read data is shown in Figure 23 on page 54. Full-speed random read accesses within a page (or pages) can be performed as shown in Figure 24 on page 55.

Data from any READ burst may be truncated with a BURST TERMINATE command, as shown in Figure 25 on page 56. The BURST TERMINATE latency is equal to the READ (CAS) latency; for example, the BURST TERMINATE command should be issued x cycles after the READ command, where x equals the number of desired data element pairs (pairs are required by the $2n$ -prefetch architecture).

Data from any READ burst must be completed or truncated before a subsequent WRITE command can be issued. If truncation is necessary, the BURST TERMINATE command must be used, as shown in Figure 26 on page 57. A READ burst may be followed by, or truncated with, a PRECHARGE command to the same bank provided that auto precharge was not activated. The PRECHARGE command should be issued x cycles after the READ command, where x equals the number of desired data element pairs. This is shown in Figure 27 on page 58. Following the PRECHARGE command, a subsequent command to the same bank cannot be issued until t_{RP} is met. Part of the row precharge time is hidden during the access of the last data elements.

Figure 21: READ Burst

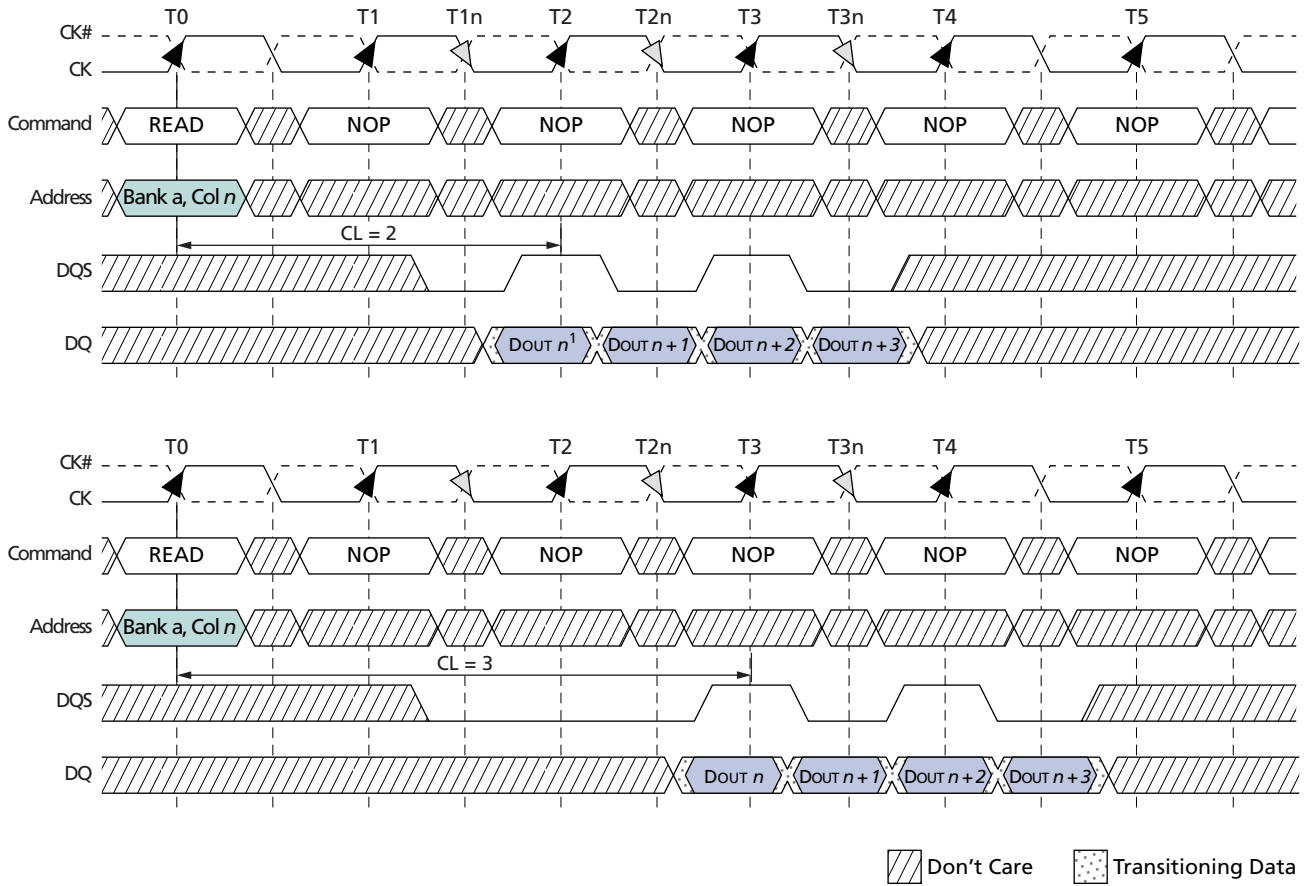

- Notes:
1. DOUT n = data-out from column n .
 2. BL = 4.
 3. Shown with nominal t_{AC} , t_{DQSK} , and t_{DQSQ} .

Figure 22: Consecutive READ Bursts

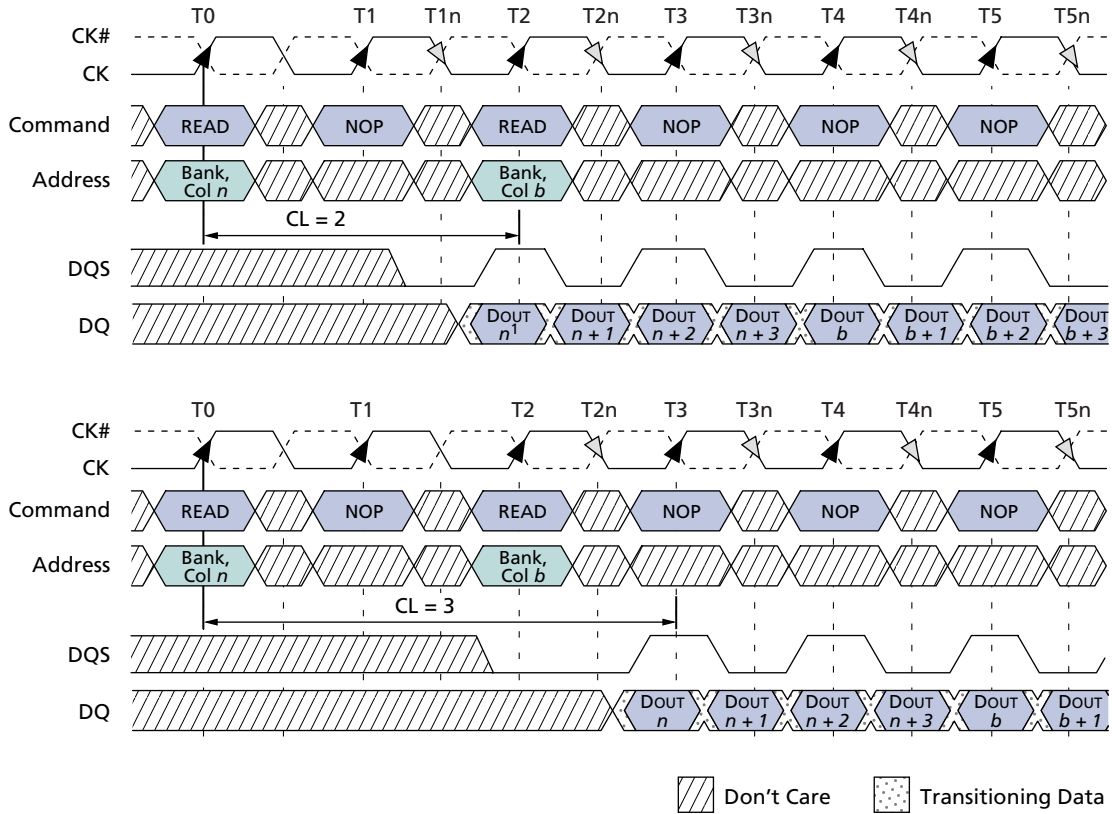

- Notes:
1. DOUT n (or b) = data-out from column n (or column b).
 2. BL = 4, 8, or 16 (if 4, the bursts are concatenated; if 8 or 16, the second burst interrupts the first).
 3. Shown with nominal t_{AC} , t_{DQSCk} , and t_{DQSQ} .
 4. Example applies only when READ commands are issued to same device.

Figure 23: Nonconsecutive READ Bursts

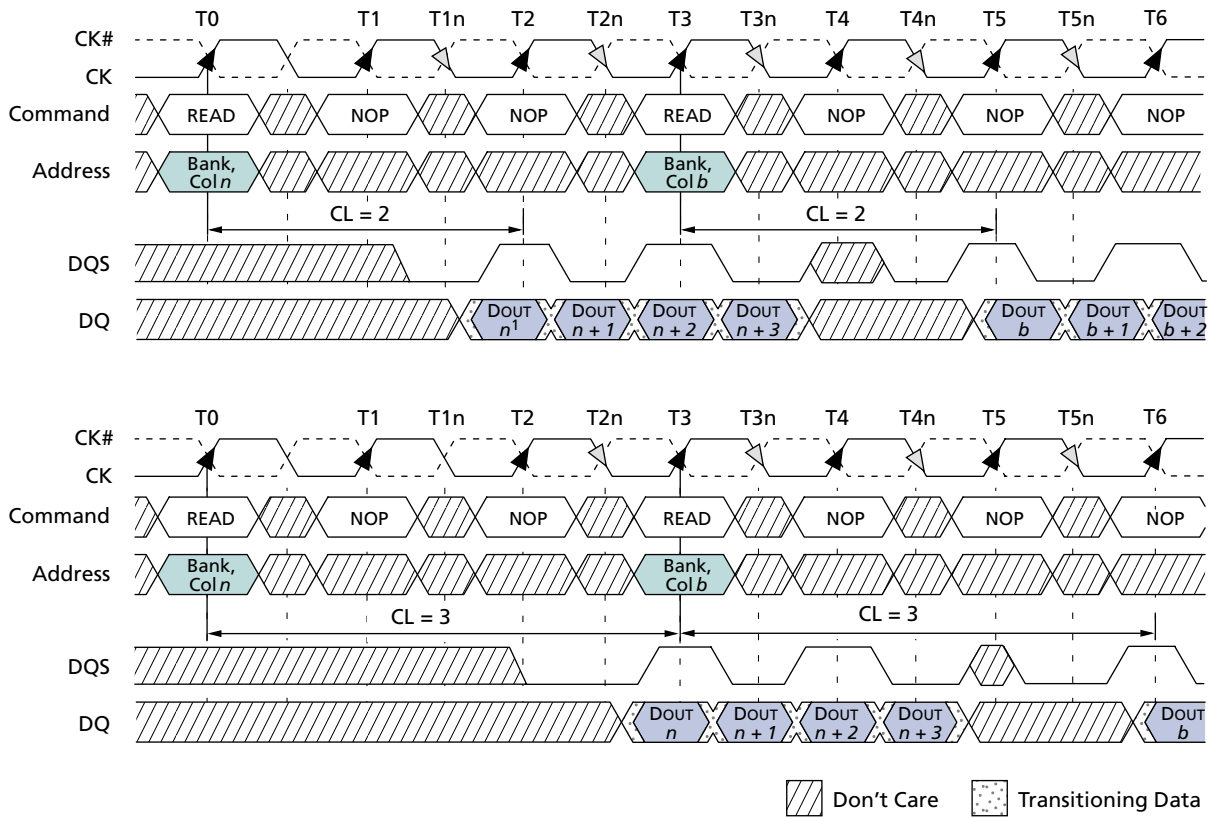

- Notes:
1. DOUT n (or b) = data-out from column n (or column b).
 2. BL = 4, 8, or 16 (if burst is 8 or 16, the second burst interrupts the first).
 3. Shown with nominal t_{AC} , t_{DQSCK} , and t_{DQSQ} .
 4. Example applies when READ commands are issued to different devices or nonconsecutive READs.

Figure 24: Random READ Accesses

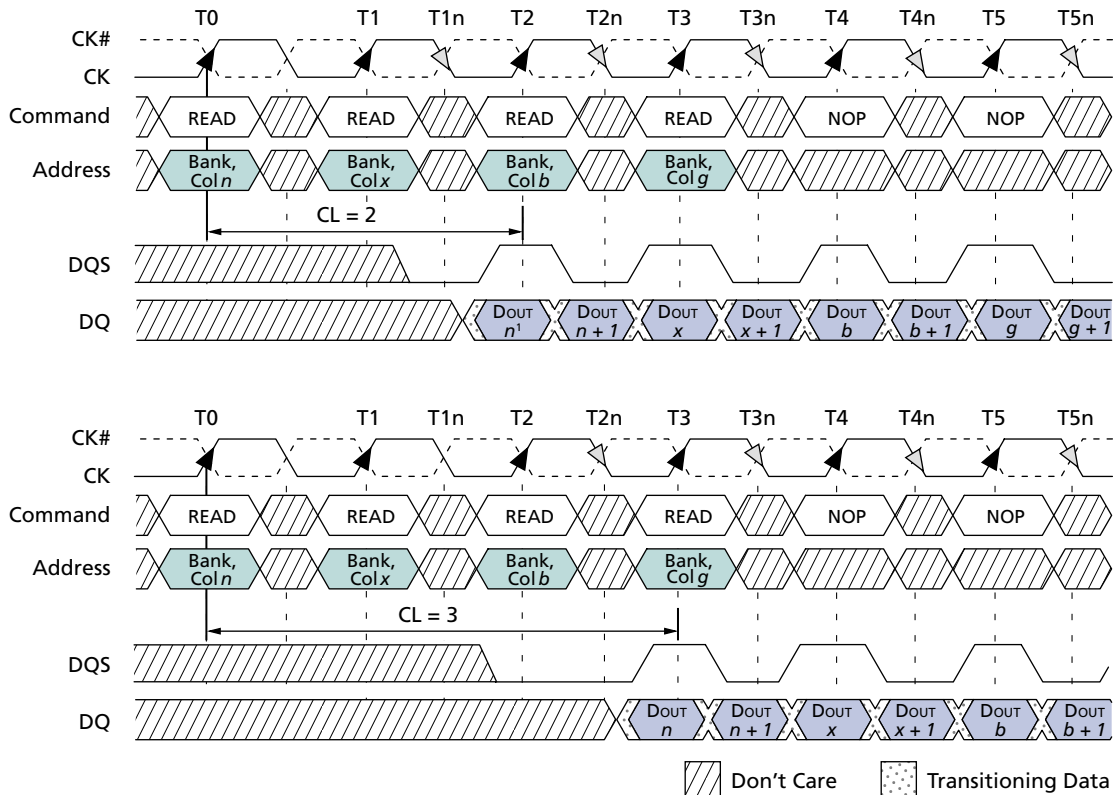

- Notes:
1. DOUT n (or x , b , g) = data-out from column n (or column x , column b , column g).
 2. BL = 2, 4, 8, or 16 (if 4, 8, or 16, the following burst interrupts the previous).
 3. READs are to an active row in any bank.
 4. Shown with nominal t_{AC} , t_{DQSCk} , and t_{DQSQ} .

Figure 25: Terminating a READ Burst

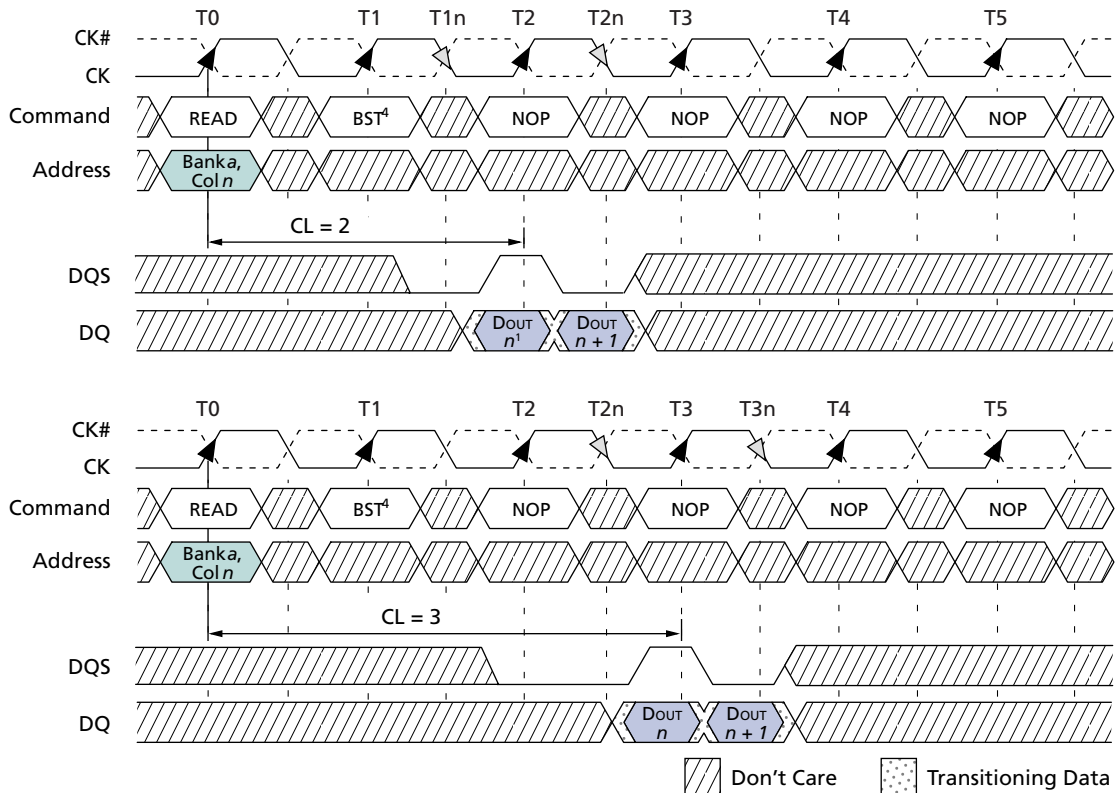

- Notes:
1. DOUT n = data-out from column n .
 2. BL = 4, 8, or 16.
 3. Shown with nominal t_{AC} , t_{DOSCK} , and t_{DOSQ} .
 4. BST = BURST TERMINATE command; page remains open.
 5. CKE = HIGH.

Figure 26: READ-to-WRITE

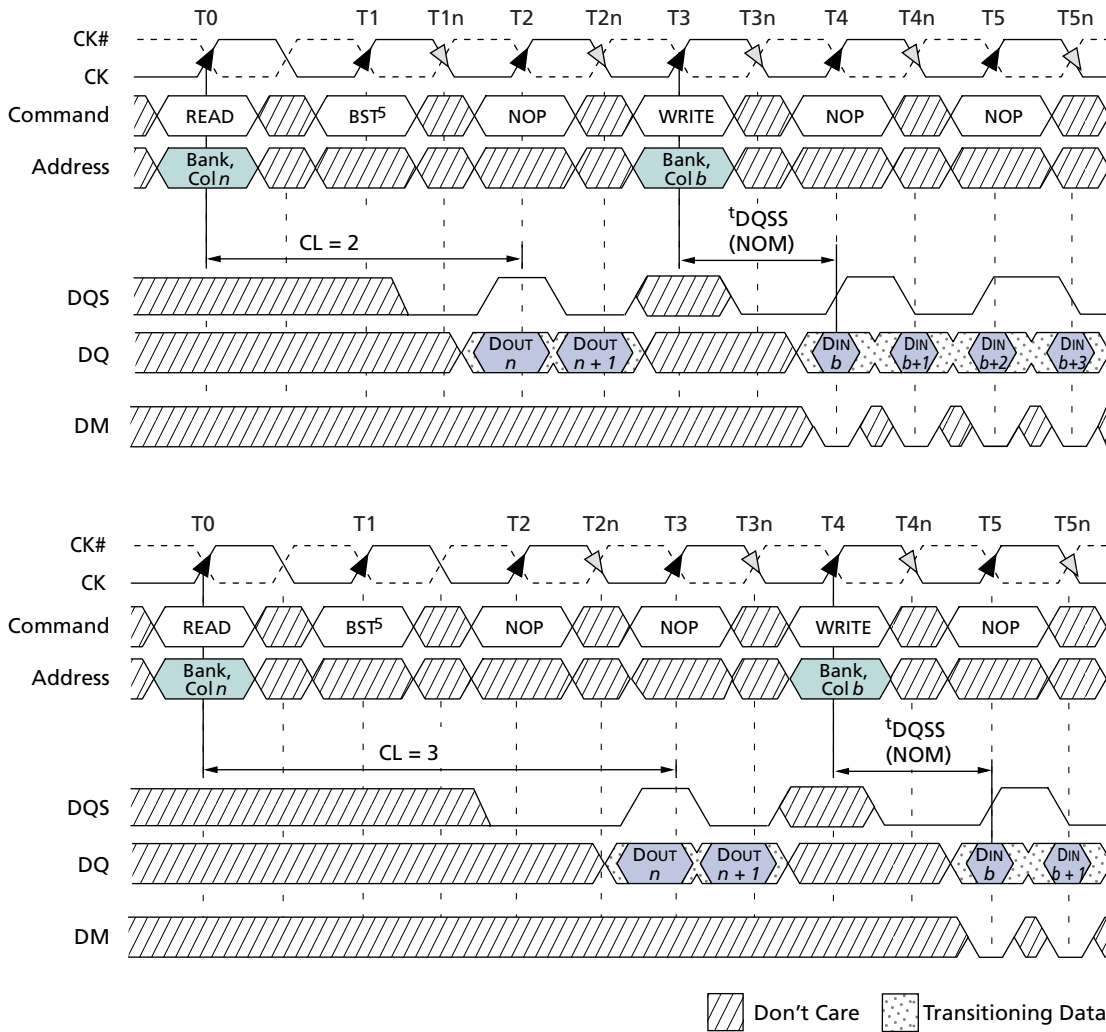

- Notes:
1. DOUT n = data-out from column n .
 2. DIN b = data-in from column b .
 3. BL = 4 in the cases shown (applies for bursts of 8 and 16as well; if BL = 2, the BST command shown can be a NOP).
 4. Shown with nominal t_{AC} , t_{DQSK} , and t_{DQSQ} .
 5. BST = BURST TERMINATE command; page remains open.
 6. CKE = HIGH.

Figure 27: READ-to-PRECHARGE

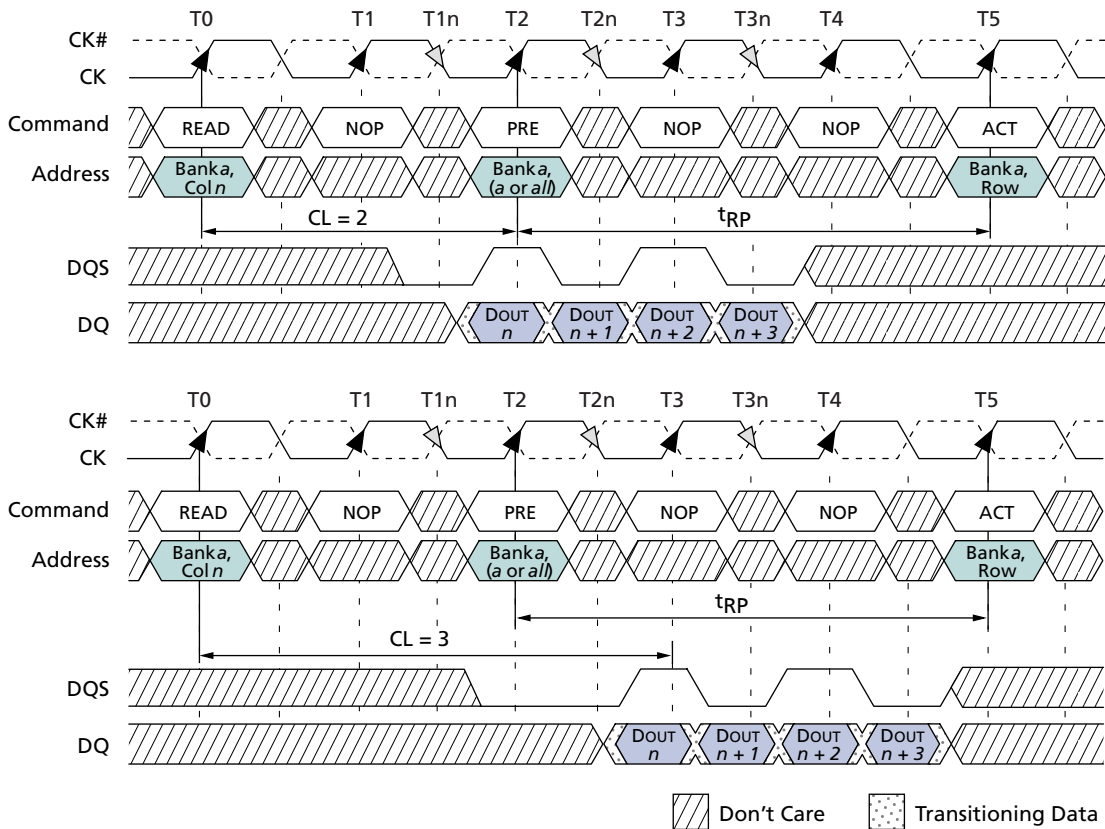

- Notes:
1. DOUT n = data-out from column n .
 2. BL = 4, or an interrupted burst of 8 or 16.
 3. Shown with nominal t_{AC} , t_{DQSCK} , and t_{DQSQ} .
 4. READ-to-PRECHARGE equals 2 clocks, which enables 2 data pairs of data-out.
 5. A READ command with auto precharge enabled, provided t_{RAS} (MIN) is met, would cause a precharge to be performed at x number of clock cycles after the READ command, where $x = BL/2$.
 6. PRE = PRECHARGE command; ACT = ACTIVE command.

Figure 28: Data Output Timing – t_{DQSQ} , t_{QH} , and Data Valid Window (x16)

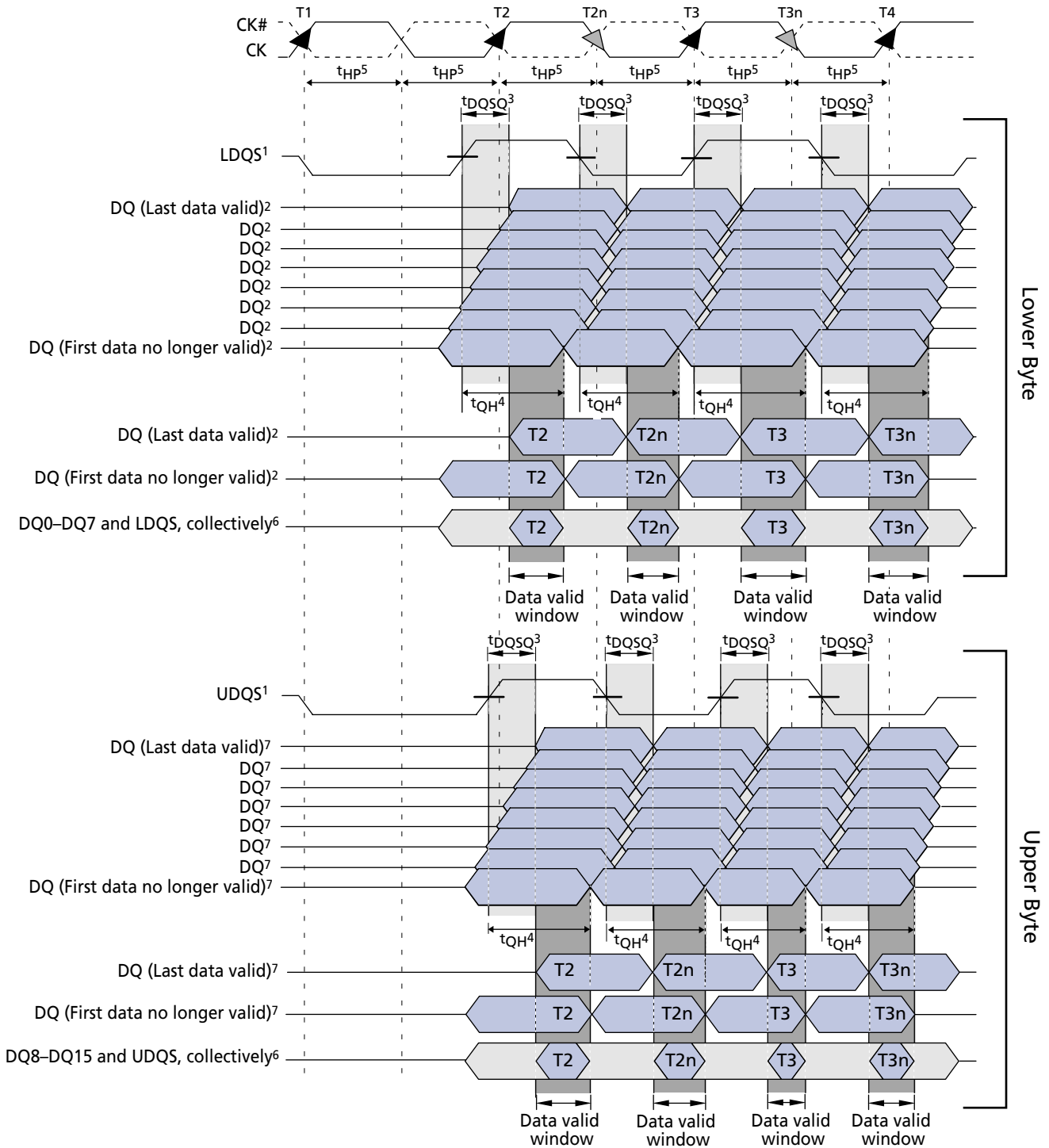

- Notes: 1. DQ transitioning after DQS transitions define the t_{DQSQ} window. LDQS defines the lower byte and UDQS defines the upper byte.
2. DQ0, DQ1, DQ2, DQ3, DQ4, DQ5, DQ6, or DQ7.

3. t_{DQSQ} is derived at each DQS clock edge and is not cumulative over time and begins with DQS transition and ends with the last valid DQ transition.
4. t_{QH} is derived from t_{HP} : $t_{QH} = t_{HP} - t_{QHS}$.
5. t_{HP} is the lesser of t_{CL} or t_{CH} clock transition collectively when a bank is active.
6. The data valid window is derived for each DQS transitions and is defined as $t_{QH} - t_{DQSQ}$.
7. DQ8, DQ9, DQ10, DQ11, DQ12, DQ13, DQ14, or DQ15.

Figure 29: Data Output Timing - t_{DQSQ} , t_{QH} , and Data Valid Window (x32)

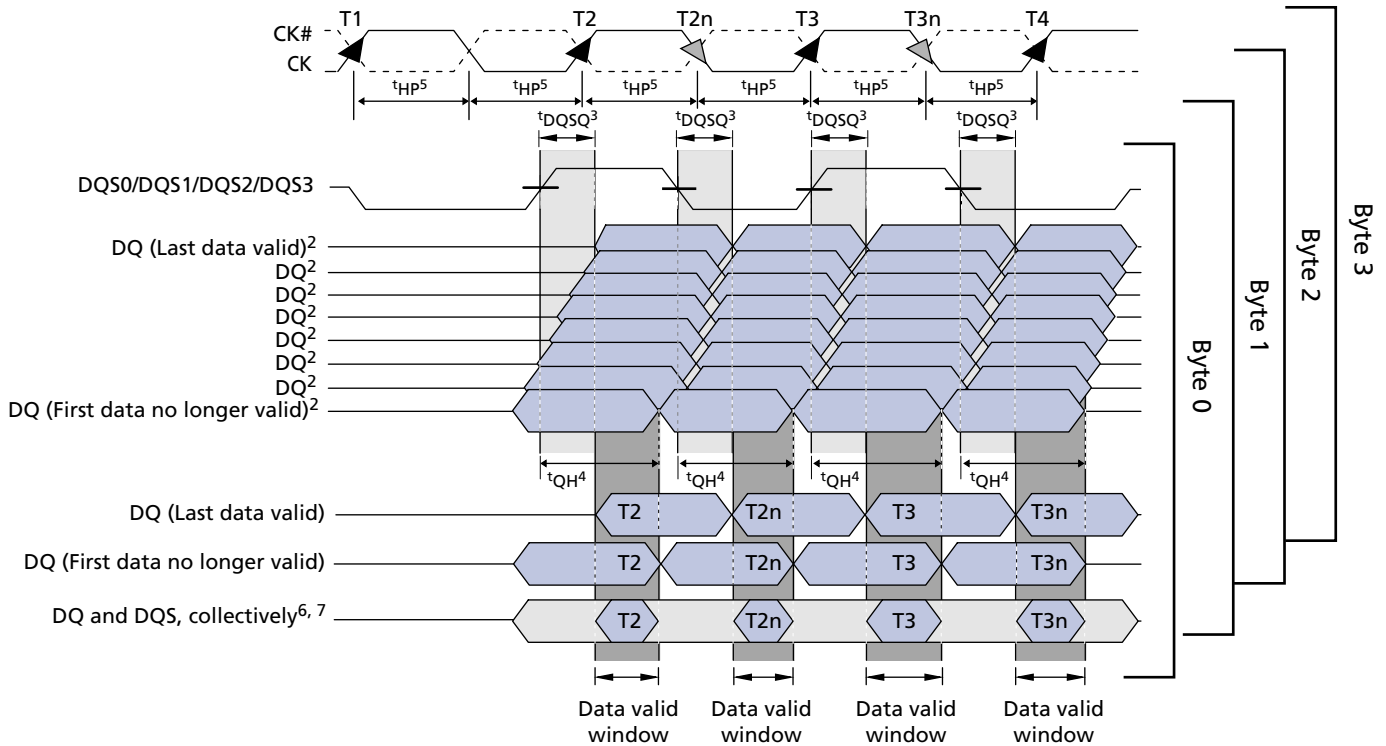

- Notes:
1. DQ transitioning after DQS transitions define the t_{DQSQ} window.
 2. Byte 0 is DQ0...7, byte 1 is DQ8...15, byte 2 is DQ16...23, byte 3 is DQ24...31.
 3. t_{DQSQ} is derived at each DQS clock edge and is not cumulative over time and begins with DQS transition and ends with the last valid DQ transition.
 4. t_{QH} is derived from t_{HP} : $t_{QH} = t_{HP} - t_{QHS}$.
 5. t_{HP} is the lesser of t_{CL} or t_{CH} clock transition collectively when a bank is active.
 6. The data valid window is derived for each DQS transition and is $t_{QH} - t_{DQSQ}$.
 7. DQ[7:0] and DQS0 for byte 0; DQ[15:8] and DQS1 for byte 1; DQ[23:16] and DQS2 for byte 2; DQ[31:23] and DQS3 for byte 3.

Figure 30: Data Output Timing – t_{AC} and t_{DQSK}

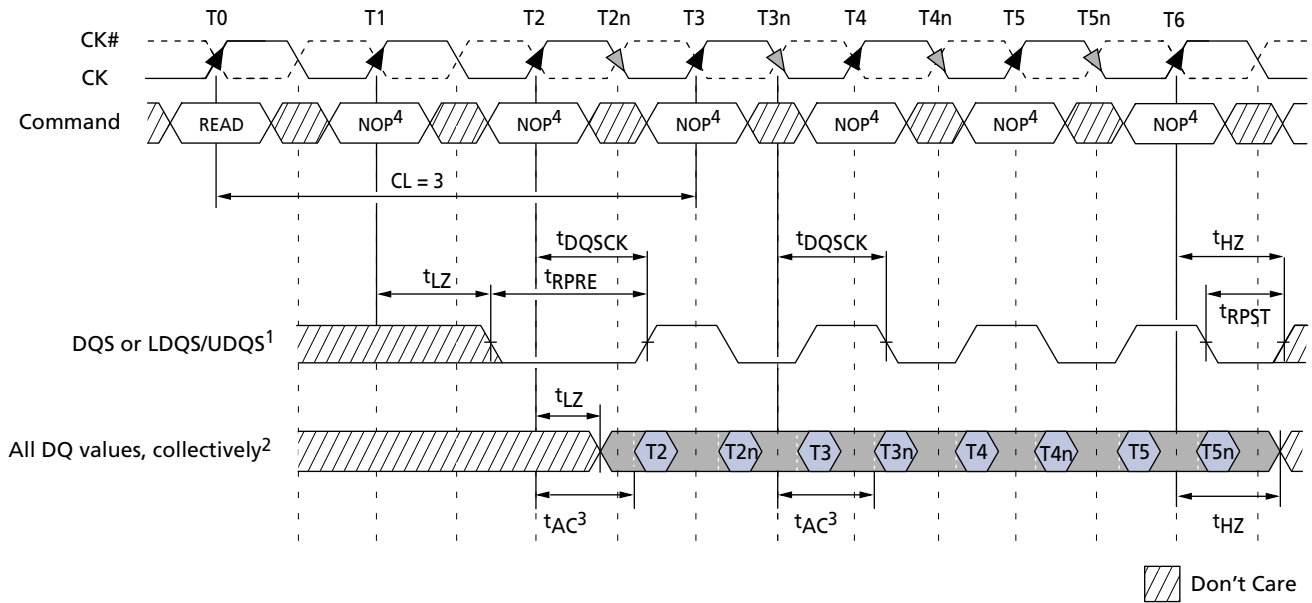

- Notes:
1. DQ transitioning after DQS transitions define t_{DQSQ} window.
 2. All DQ must transition by t_{DQSQ} after DQS transitions, regardless of t_{AC} .
 3. t_{AC} is the DQ output window relative to CK and is the "long-term" component of DQ skew.
 4. Commands other than NOP may be valid during this cycle.

WRITES

WRITE bursts are initiated with a WRITE command, as shown in Figure 11 on page 32. The starting column and bank addresses are provided with the WRITE command, and auto precharge is either enabled or disabled for that access. If auto precharge is enabled, the row being accessed is precharged at the completion of the burst. For the WRITE commands used in the following illustrations, auto precharge is disabled. Basic data input timing is shown in Figure 31 on page 63 (this timing applies to all WRITE operations).

Input data appearing on the data bus is written to the memory array subject to the state of data mask DM inputs coincident with the data. If DM is registered LOW, the corresponding data will be written; if DM is registered HIGH, the corresponding data will be ignored, and the write will not be executed to that byte/column location. DM operation is illustrated in Figure 32 on page 64.

During WRITE bursts, the first valid data-in element will be registered on the first rising edge of DQS following the WRITE command, and subsequent data elements will be registered on successive edges of DQS. The LOW state on DQS between the WRITE command and the first rising edge is known as the write preamble; the LOW state on DQS following the last data-in element is known as the write postamble. The WRITE burst is complete when the write postamble and t^{WR} or t^{WTR} are satisfied.

The time between the WRITE command and the first corresponding rising edge of DQS (t^{DQSS}) is specified with a relatively wide range (from 75 percent to 125 percent of one clock cycle). All of the WRITE diagrams show the nominal case, and where the two extreme cases (that is, $t^{\text{DQSS}} [\text{MIN}]$ and $t^{\text{DQSS}} [\text{MAX}]$) might not be intuitive, they have also been included. Figure 33 on page 65 shows the nominal case and the extremes of t^{DQSS} for a burst of 4. Upon completion of a burst, assuming no other commands have been initiated, the DQs will remain High-Z and any additional input data will be ignored.

Data for any WRITE burst may be concatenated with or truncated by a subsequent WRITE command. In either case, a continuous flow of input data can be maintained. The new WRITE command can be issued on any positive edge of clock following the previous WRITE command. The first data element from the new burst is applied after either the last element of a completed burst or the last desired data element of a longer burst that is being truncated. The new WRITE command should be issued x cycles after the first WRITE command, where x equals the number of desired data element pairs (pairs are required by the $2n$ -prefetch architecture).

Figure 34 on page 66 shows concatenated bursts of 4. An example of nonconsecutive WRITES is shown in Figure 35 on page 66. Full-speed random write accesses within a page or pages can be performed, as shown in Figure 36 on page 67.

Data for any WRITE burst may be followed by a subsequent READ command. To follow a WRITE without truncating the WRITE burst, t^{WTR} should be met, as shown in Figure 37 on page 68.

Data for any WRITE burst may be truncated by a subsequent READ command, as shown in Figure 38 on page 69. Note that only the data-in pairs that are registered prior to the t^{WTR} period are written to the internal array, and any subsequent data-in should be masked with DM, as shown in Figure 39 on page 70.

Data for any WRITE burst may be followed by a subsequent PRECHARGE command. To follow a WRITE without truncating the WRITE burst, t^{WR} should be met, as shown in Figure 40 on page 71.

Data for any WRITE burst may be truncated by a subsequent PRECHARGE command, as shown in Figure 41 on page 72 and Figure 42 on page 73. Note that only the data-in pairs that are registered prior to the t_{WR} period are written to the internal array, and any subsequent data-in should be masked with DM, as shown in Figure 41 and Figure 42. After the PRECHARGE command, a subsequent command to the same bank cannot be issued until t_{RP} is met.

Figure 31: Data Input Timing

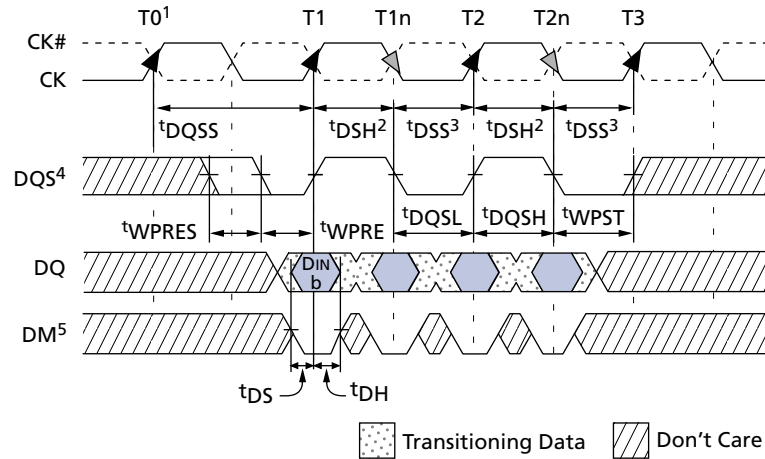

- Notes:
1. WRITE command issued at T_0 .
 2. t_{DSH} (MIN) generally occurs during t_{DQSS} (MIN).
 3. t_{DSS} (MIN) generally occurs during t_{DQSS} (MAX).
 4. For x16, LDQS controls the lower byte; UDQS controls the upper byte. For x32, DQS0 controls DQ[7:0], DQS1 controls DQ[15:8], DQS2 controls DQ[23:16], and DQS3 controls DQ[31:24].
 5. For x16, LDM controls the lower byte; UDM controls the upper byte. For x32, DM0 controls DQ[7:0], DM1 controls DQ[15:8], DM2 controls DQ[23:16], and DM3 controls DQ[31:24].

Figure 32: Write – DM Operation

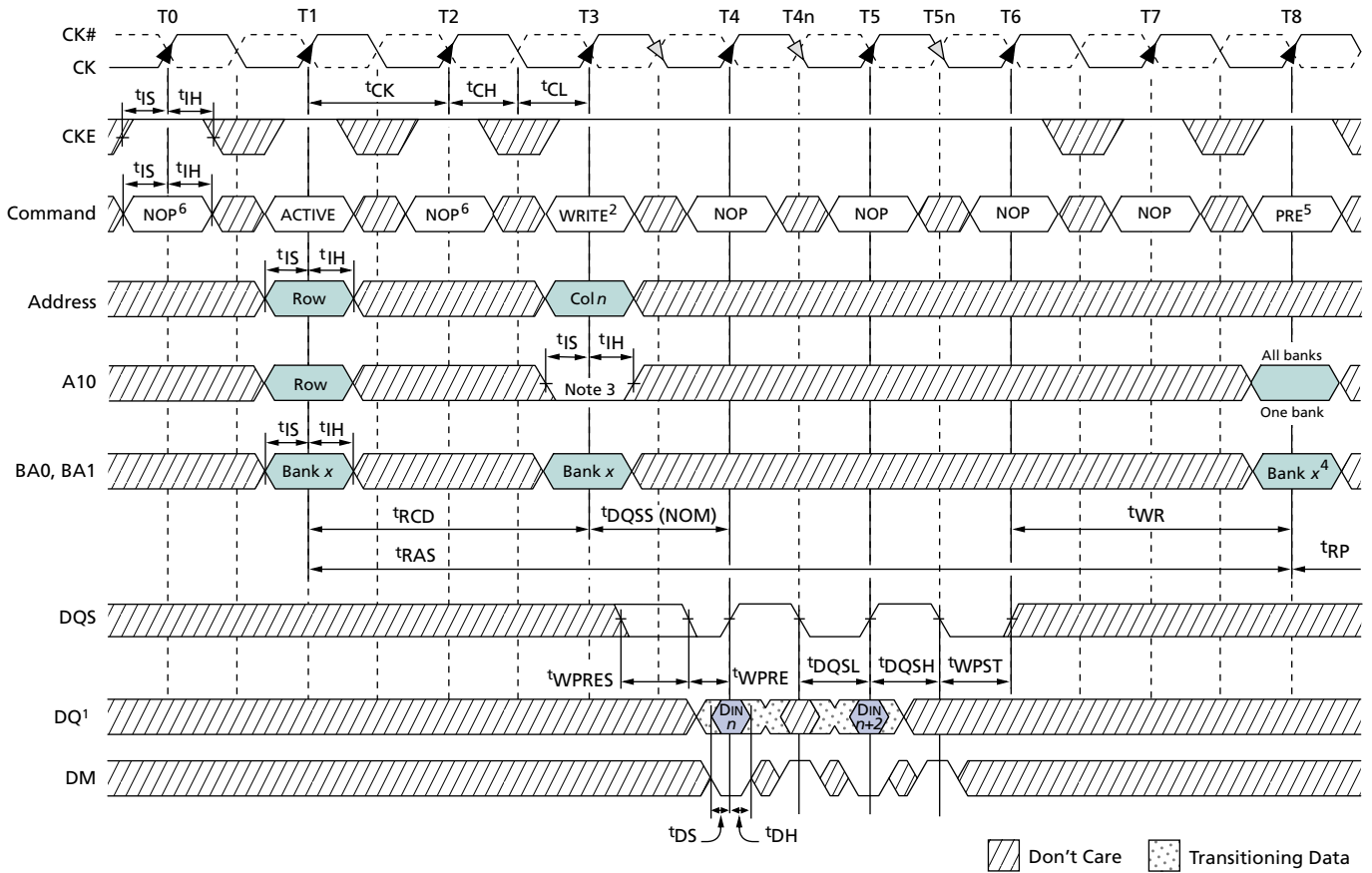

- Notes:
1. $DIN\ n$ = data-in from column n .
 2. $BL = 4$ in the case shown.
 3. Disable auto precharge.
 4. Bank x at T8 is "Don't Care" if A10 is HIGH at T8.
 5. PRE = PRECHARGE.
 6. NOP commands are shown for ease of illustration; other commands may be valid at these times.

Figure 33: WRITE Burst

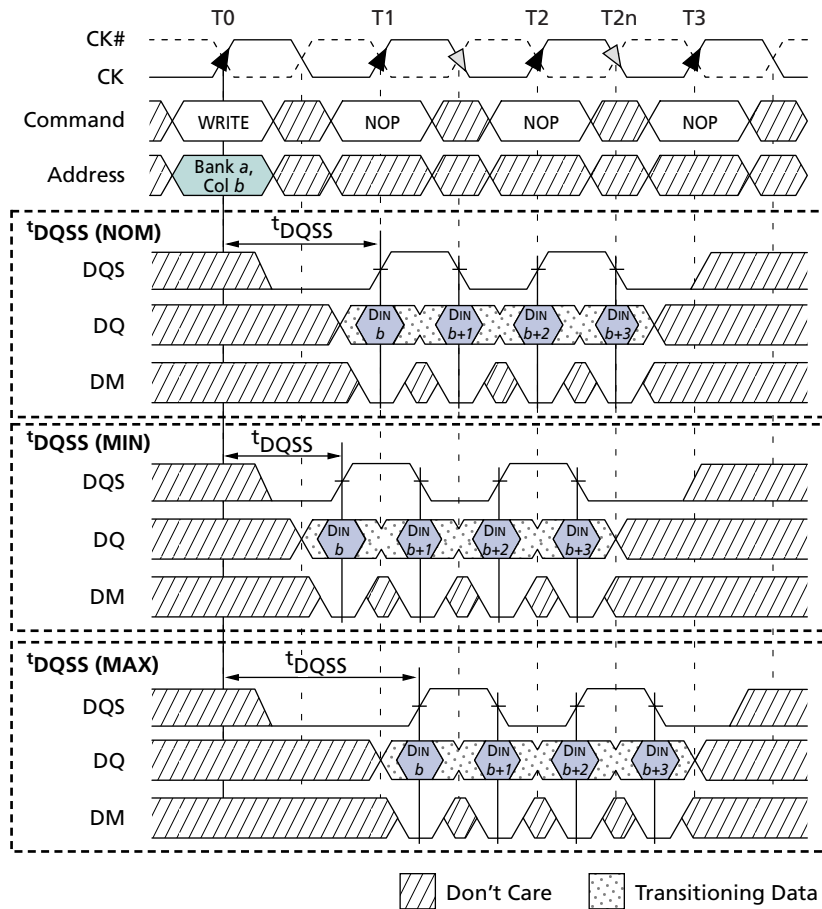

- Notes:
1. DIN b = data-in for column b .
 2. An uninterrupted burst of 4 is shown.
 3. A10 is LOW with the WRITE command (auto precharge is disabled).

Figure 34: Consecutive WRITE-to-WRITE

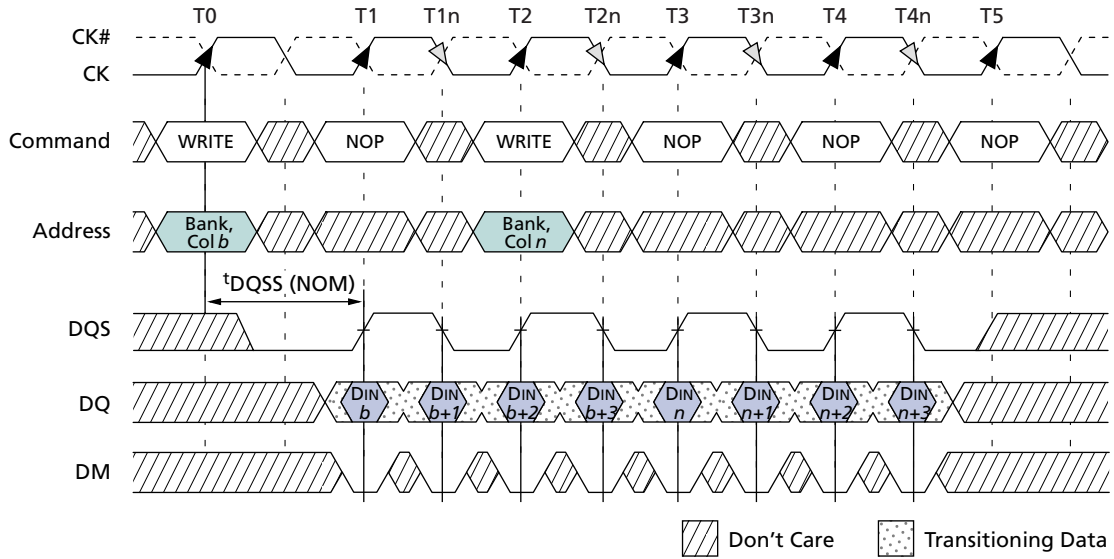

- Notes:
1. $DIN\ b\ (n)$ = data-in for column $b\ (n)$.
 2. An uninterrupted burst of 4 is shown.
 3. Each WRITE command may be to any bank.

Figure 35: Nonconsecutive WRITE-to-WRITE

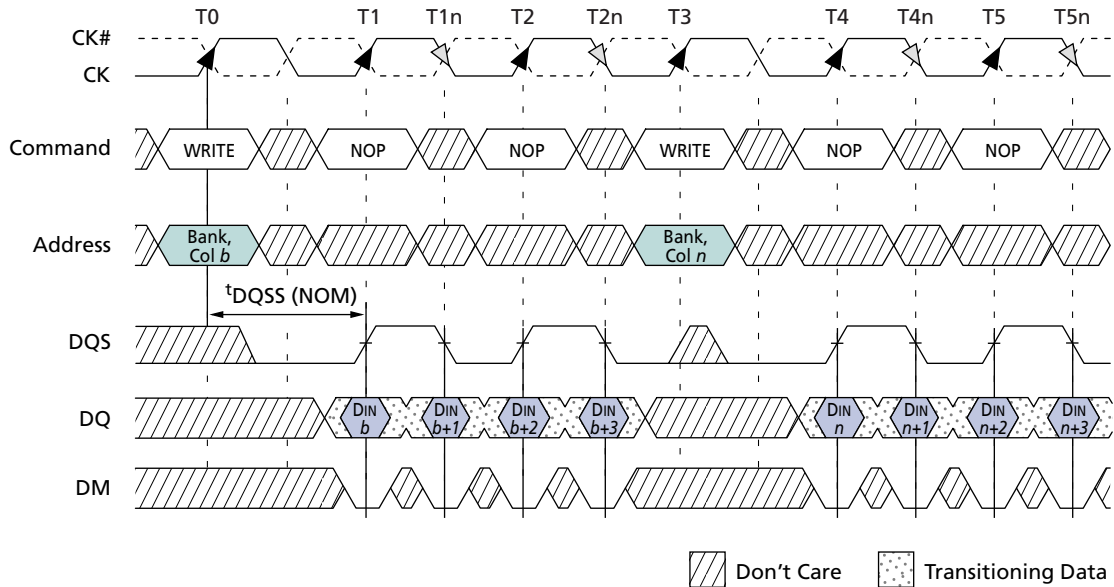

- Notes:
1. $DIN\ b\ (n)$ = data-in for column $b\ (n)$.
 2. An uninterrupted burst of 4 is shown.
 3. Each WRITE command may be to any bank.

Figure 36: Random WRITE Cycles

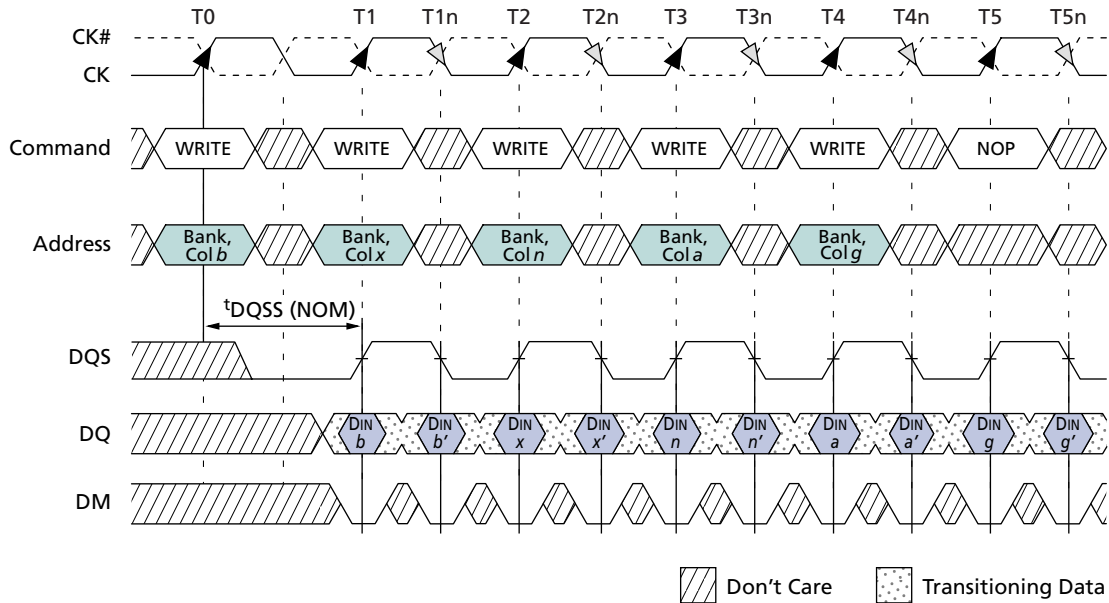

- Notes:
1. $DIN\ b$ (or x, n, a, g) = data-in for column b (or x, n, q, g).
 2. b' (or x, n, a, g) = the next data-in following $DIN\ b$ (x, n, a, g) according to the programmed burst order.
 3. Programmed BL = 2, 4, 8, or 16 in cases shown.
 4. Each WRITE command may be to any bank.

Figure 37: WRITE-to-READ – Uninterrupting

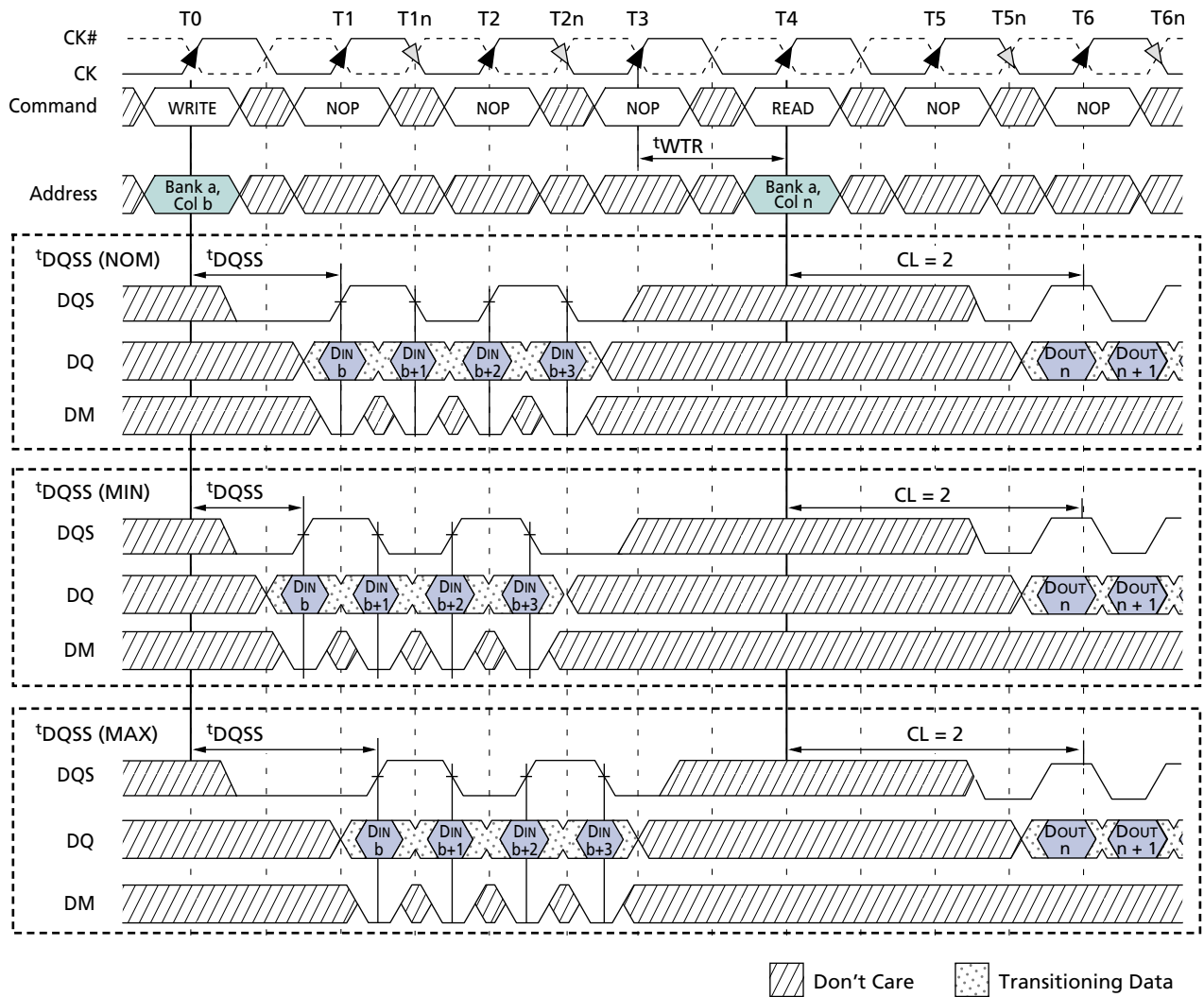

- Notes:
1. $DIN\ b$ = data-in for column b ; $DOUT\ n$ = data-out for column n .
 2. An uninterrupted burst of 4 is shown.
 3. t_{WTR} is referenced from the first positive CK edge after the last data-in pair.
 4. The READ and WRITE commands are to the same device. However, the READ and WRITE commands may be to different devices, in which case t_{WTR} is not required and the READ command could be applied earlier.
 5. A10 is LOW with the WRITE command (auto precharge is disabled).

Figure 38: WRITE-to-READ - Interrupting

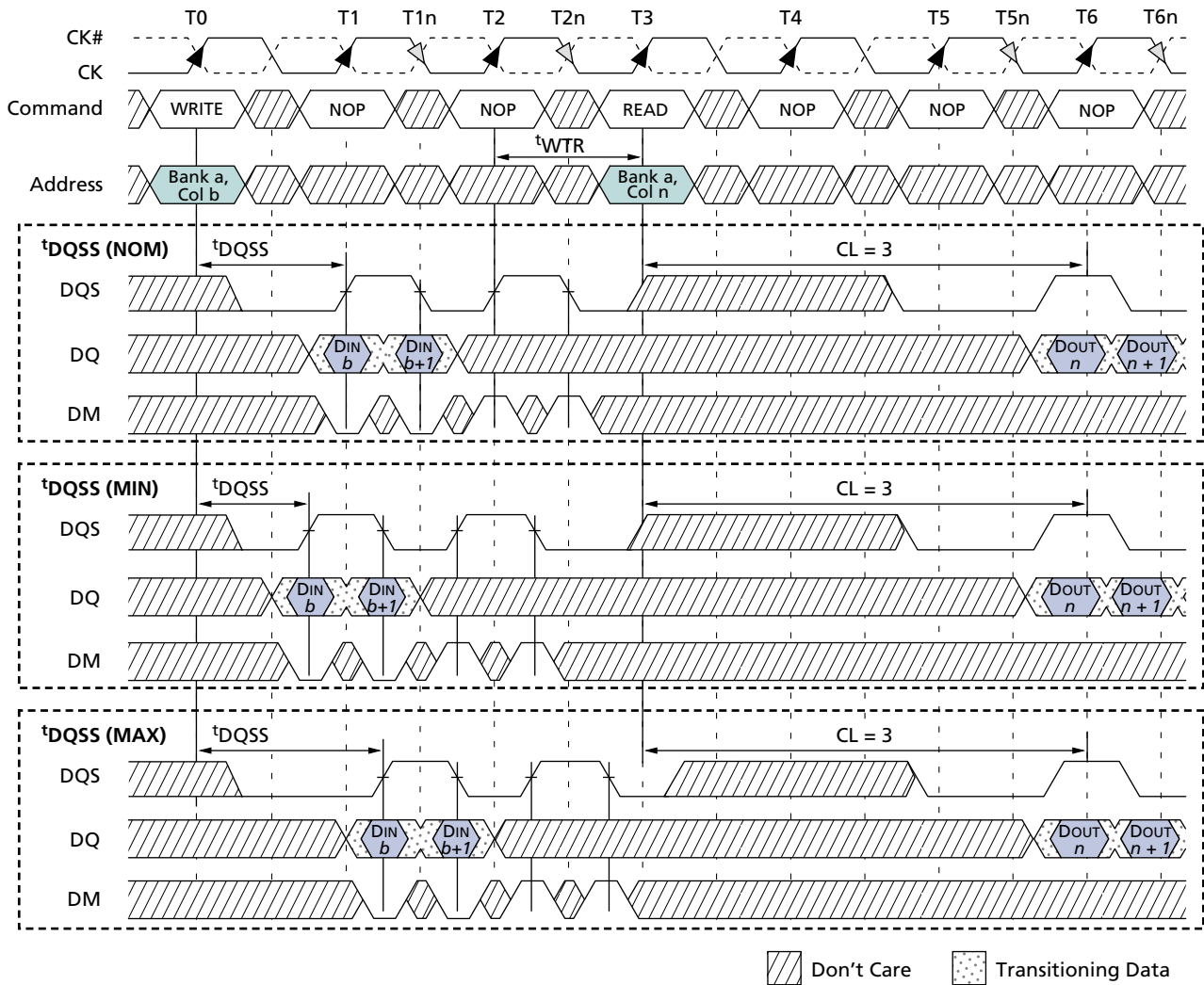

- Notes:
1. DIN b = data-in for column b ; DOUT n = data-out for column n .
 2. An interrupted burst of 4 is shown; two data elements are written.
 3. t_{WTR} is referenced from the first positive CK edge after the last data-in pair.
 4. A10 is LOW with the WRITE command (auto precharge is disabled).
 5. DQS is required at T2 and T2n (nominal case) to register DM.

Figure 39: WRITE-to-READ – Odd Number of Data, Interrupting

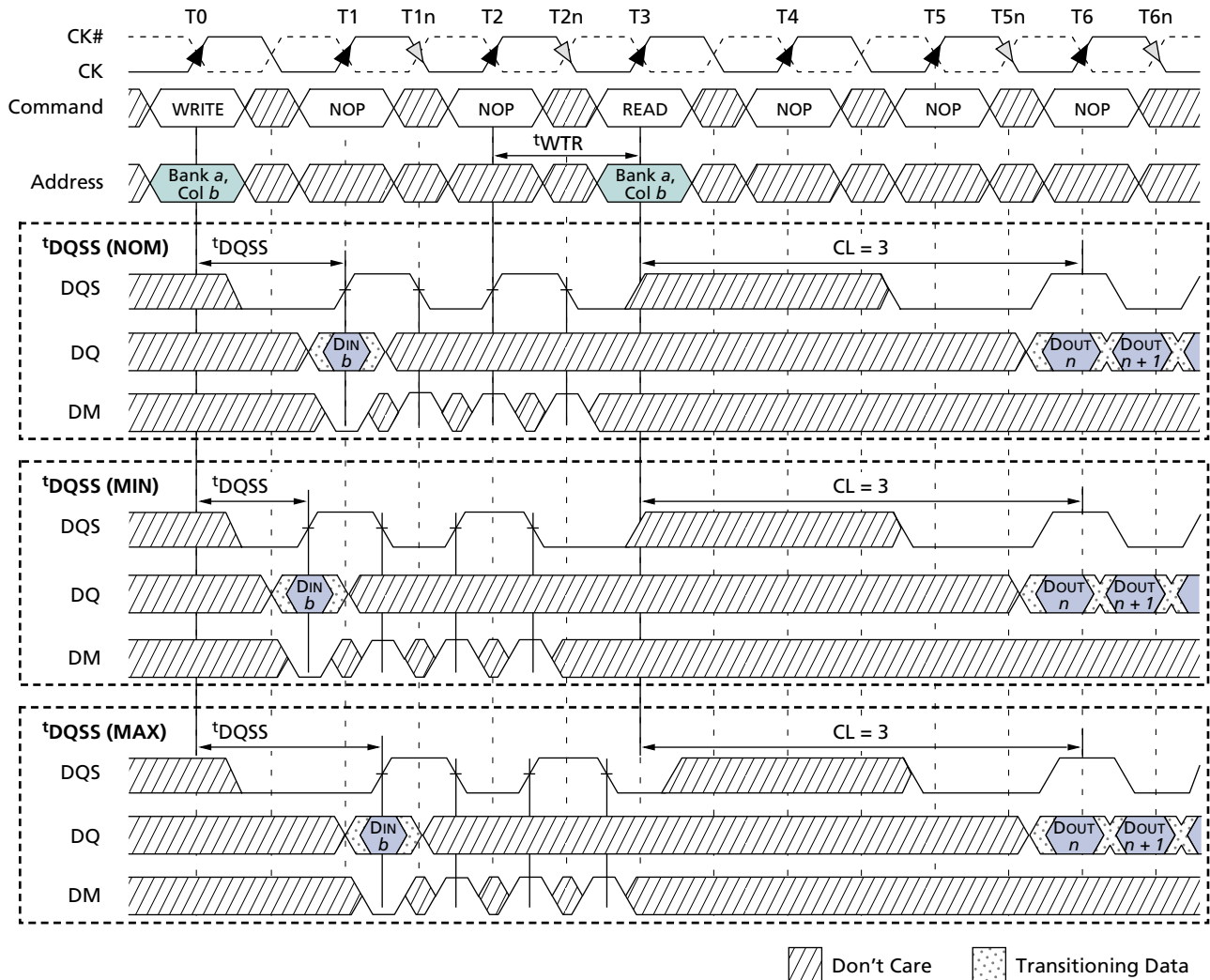

- Notes:
1. DIN b = data-in for column b ; DOUT n = data-out for column n .
 2. An interrupted burst of 4 is shown; one data element is written, three are masked.
 3. t_{WTR} is referenced from the first positive CK edge after the last data-in pair.
 4. A10 is LOW with the WRITE command (auto precharge is disabled).
 5. DQS is required at T2 and T2n (nominal case) to register DM.

Figure 40: WRITE-to-PRECHARGE - Uninterrupting

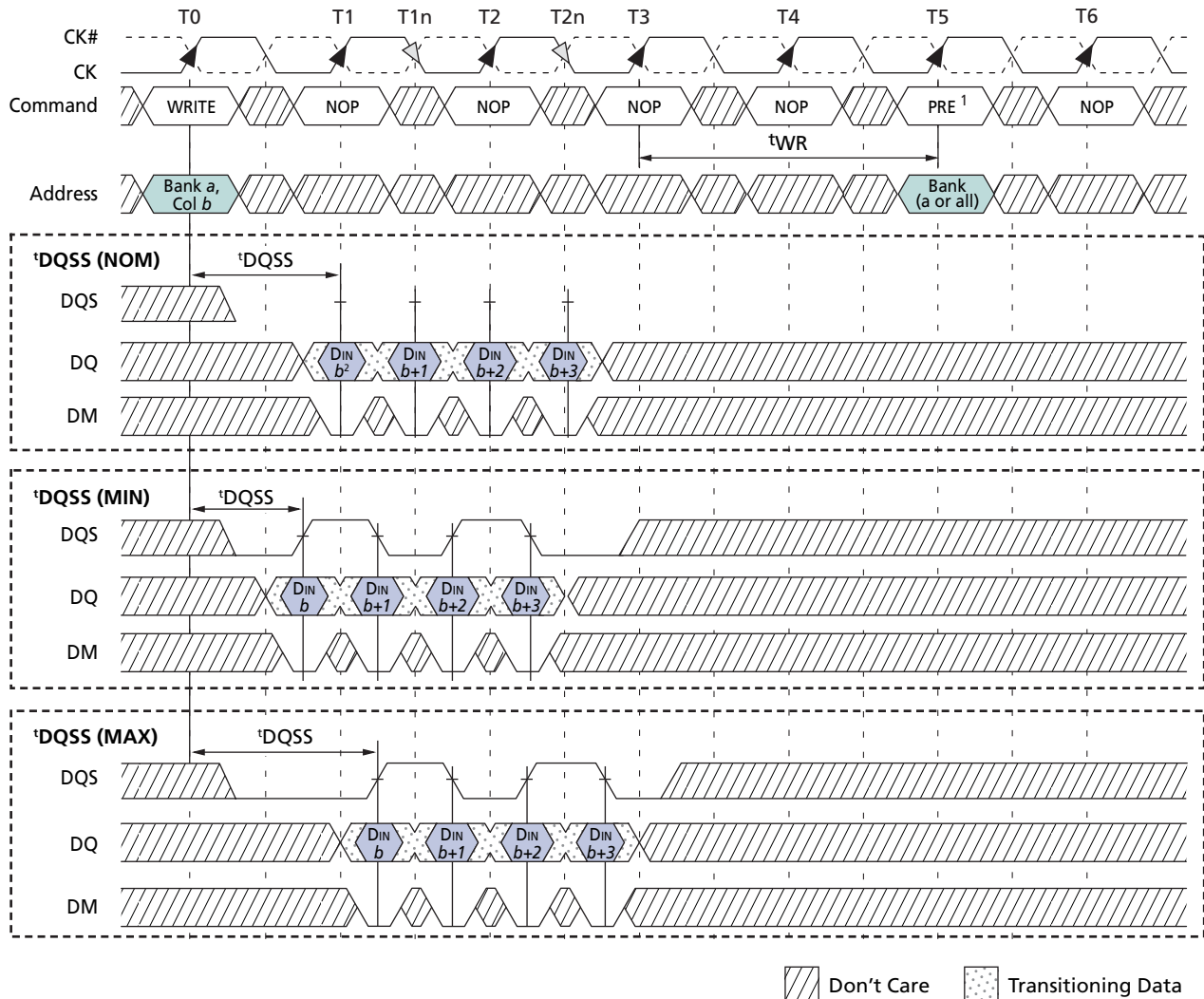

- Notes:
1. PRE = PRECHARGE.
 2. $DIN\ b$ = data-in for column b .
 3. An uninterrupted burst 4 of is shown.
 4. A10 is LOW with the WRITE command (auto precharge is disabled).
 5. t_{WR} is referenced from the first positive CK edge after the last data-in pair.
 6. The PRECHARGE and WRITE commands are to the same device. However, the PRECHARGE and WRITE commands can be to different devices; in this case, t_{WR} is not required and the PRECHARGE command can be applied earlier.

Figure 41: WRITE-to-PRECHARGE - Interrupting

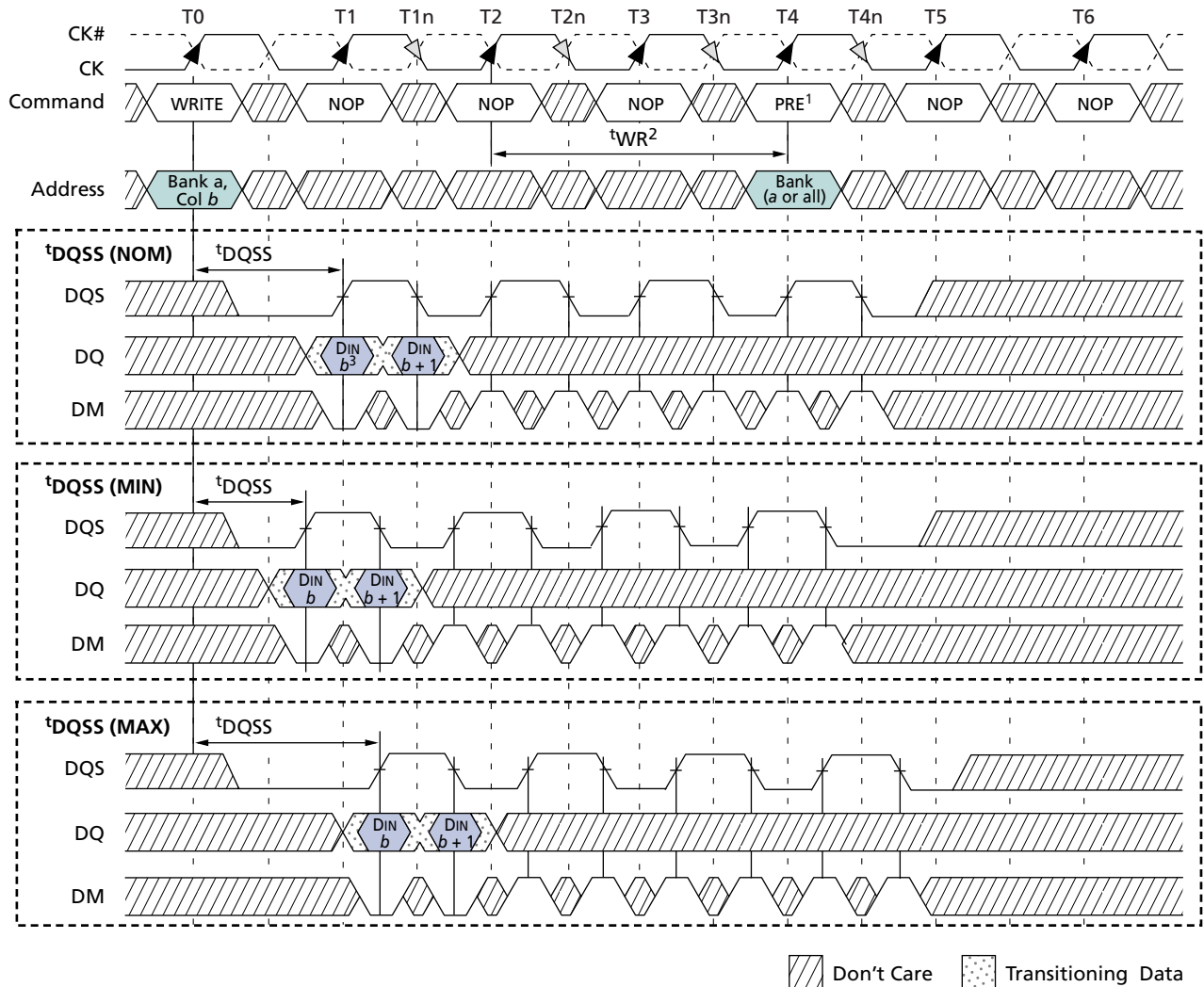

- Notes:
1. PRE = PRECHARGE.
 2. t_{WR} is referenced from the first positive CK edge after the last data-in pair.
 3. $DIN\ b$ = data-in for column b .
 4. An interrupted burst of 8 is shown; two data elements are written.
 5. A10 is LOW with the WRITE command (auto precharge is disabled).
 6. DQS is required at T4 and T4n to register DM.

Figure 42: WRITE-to-PRECHARGE – Odd Number of Data, Interrupting

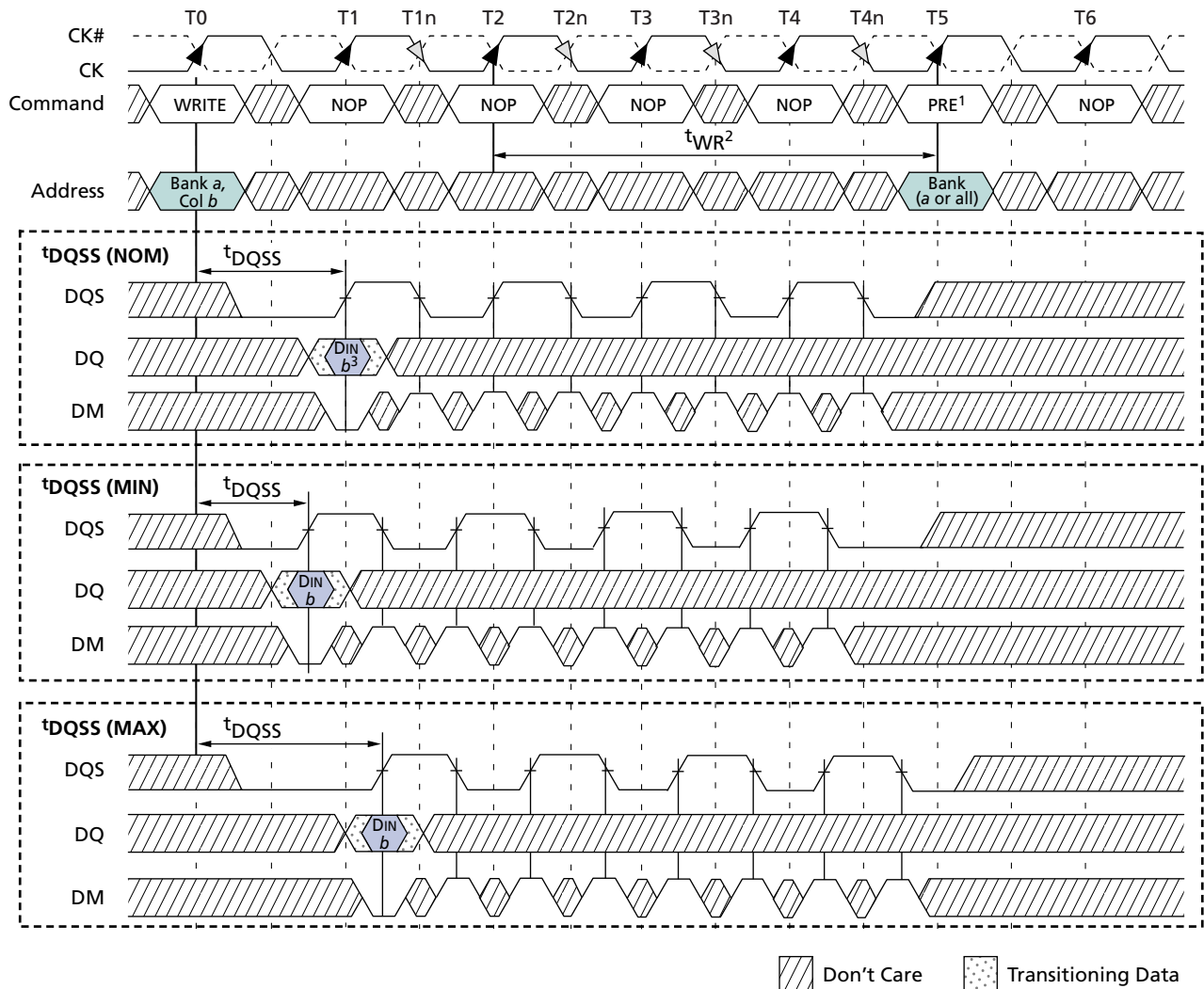

- Notes:
1. PRE = PRECHARGE.
 2. t_{WR} is referenced from the first positive CK edge after the last data-in pair.
 3. DIN_b = data-in for column b .
 4. An interrupted burst of 8 is shown; one data element is written.
 5. DQS is required at T4 and T4n to register DM.
 6. If the burst of 4 is used, DQS and DM are not required at T3, T3n, T4, and T4n.
 7. A10 is LOW with the WRITE command (auto precharge is disabled).

PRECHARGE

The PRECHARGE command is used to deactivate the open row in a particular bank or the open row in all banks. The bank(s) will be available for a subsequent row access some specified time (t_{RP}) after the PRECHARGE command is issued. Input A10 determines whether one or all banks are to be precharged, and in the case where only one bank is to be precharged (A10 = LOW), inputs BA0 and BA1 select the bank. When all banks are to be precharged (A10 = HIGH), inputs BA0 and BA1 are treated as a "Don't

Care.” After a bank has been precharged, it is in the idle state and must be activated prior to any READ or WRITE commands being issued to that bank. A PRECHARGE command will be treated as a NOP if there is no open row in that bank (idle state), or if the previously open row is already in the process of precharging.

Auto Precharge

Auto precharge is a feature that performs the same individual-bank precharge function described previously, but without requiring an explicit command. This is accomplished by using A10 to enable auto precharge in conjunction with a specific READ or WRITE command. A precharge of the bank/row that is addressed with the READ or WRITE command is automatically performed upon completion of the READ or WRITE burst. Auto precharge is nonpersistent in that it is either enabled or disabled for each individual READ or WRITE command.

Auto precharge ensures that the precharge is initiated at the earliest valid stage within a burst. This “earliest valid stage” is determined as if an explicit PRECHARGE command was issued at the earliest possible time, without violating $t^{\text{RAS}}(\text{MIN})$, as described for each burst type in “Operations” on page 36. The READ with auto precharge enabled or WRITE with auto precharge enabled states can each be broken into two parts: the access period and the precharge period. The access period starts with registration of the command and ends where the precharge period (or t^{RP}) begins. For READ with auto precharge, the precharge period is defined as if the same burst was executed with auto precharge disabled and then followed with the earliest possible PRECHARGE command that still accesses all the data in the burst. For WRITE with auto precharge, the precharge period begins when t^{WR} ends, with t^{WR} measured as if auto precharge was disabled. In addition, during a WRITE with auto precharge, at least one clock is required during t^{WR} time. During the precharge period, the user must not issue another command to the same bank until t^{RP} is satisfied.

This device supports t^{RAS} lock-out. In the case of a single READ with auto-precharge or single WRITE with auto-precharge issued at t^{RCDmin} , the internal precharge will be delayed until t^{RASmin} has been satisfied.

Bank READ operations with and without auto precharge are shown in Figure 43 on page 75 and Figure 44 on page 76. Bank WRITE operations with and without auto precharge are shown in Figure 45 on page 77 and Figure 46 on page 78.

Concurrent Auto Precharge

This device supports concurrent auto precharge such that when a READ with auto precharge is enabled or a WRITE with auto precharge is enabled, any command to another bank is supported, as long as that command does not interrupt the read or write data transfer already in process. This feature enables the precharge to complete in the bank in which the READ or WRITE with auto precharge was executed, without requiring an explicit PRECHARGE command, thus freeing the command bus for operations in other banks. During the access period of a READ or WRITE with auto precharge, only ACTIVE and PRECHARGE commands may be applied to other banks. During the precharge period, ACTIVE, PRECHARGE, READ, and WRITE commands may be applied to other banks. In either situation, all other related limitations apply (for example, contention between READ data and WRITE data must be avoided).

Figure 43: Bank Read – with Auto Precharge

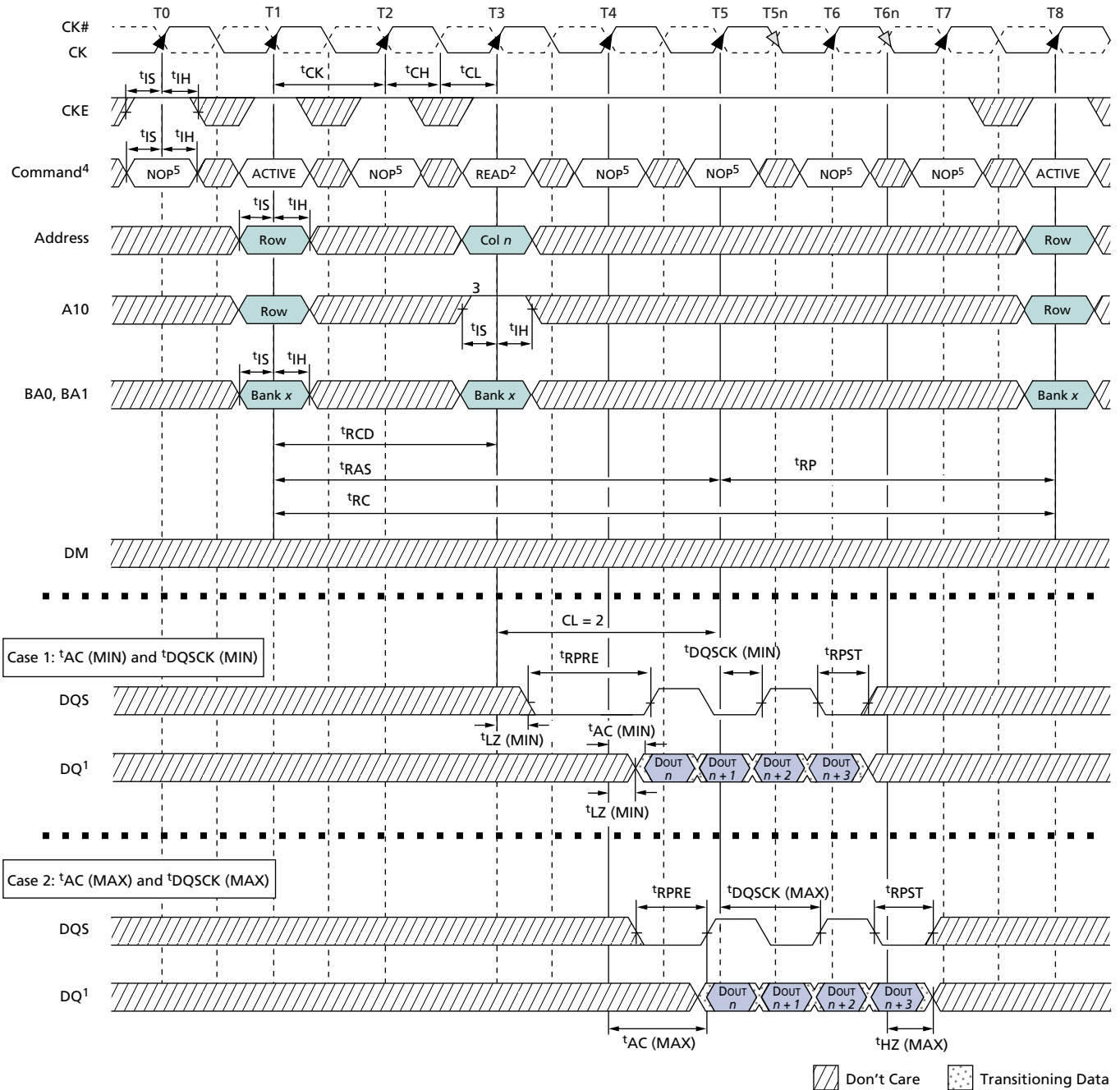

- Notes:
1. DOUT n = data-out from column n .
 2. BL = 4 in the case shown.
 3. Enable auto precharge.
 4. NOP commands are shown for ease of illustration; other commands may be valid at these times.
 5. Refer to Figure 28 on page 59 and Figure 29 on page 60 for detailed DQS and DQ timing.

Figure 44: Bank Read – Without Auto Precharge

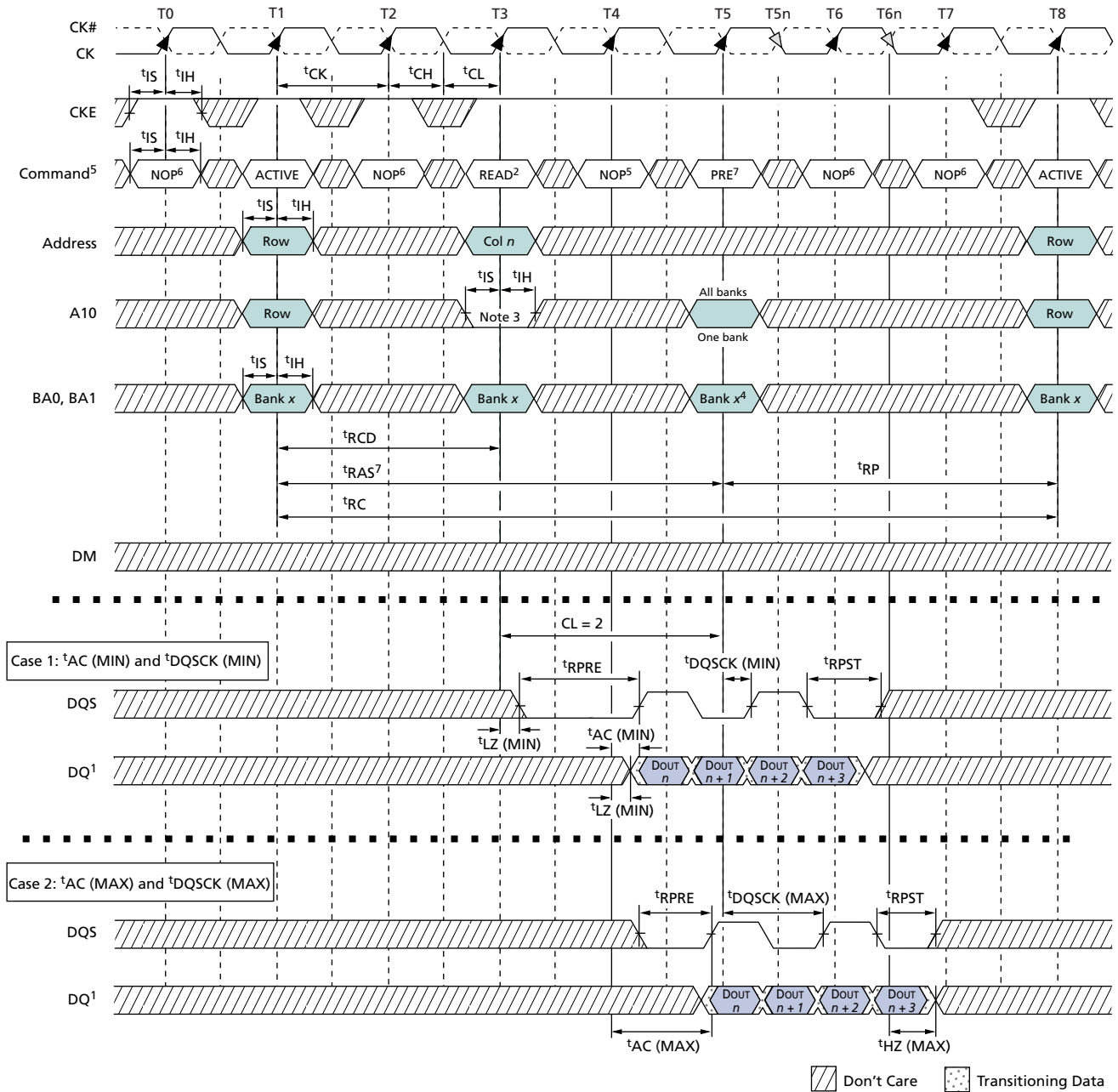

- Notes:
1. DOUT n = data out from column n .
 2. BL = 4 in the case shown.
 3. Disable auto precharge.
 4. Bank x at T5 is "Don't Care" if A10 is HIGH at T5.
 5. PRE = PRECHARGE.
 6. NOP commands are shown for ease of illustration; other commands may be valid at these times.
 7. The PRECHARGE command can only be applied at T5 if t_{RAS} (MIN) is met.
 8. Refer to Figure 28 on page 59 and Figure 29 on page 60 for DQS and DQ timing details.

Figure 45: Bank Write - with Auto Precharge

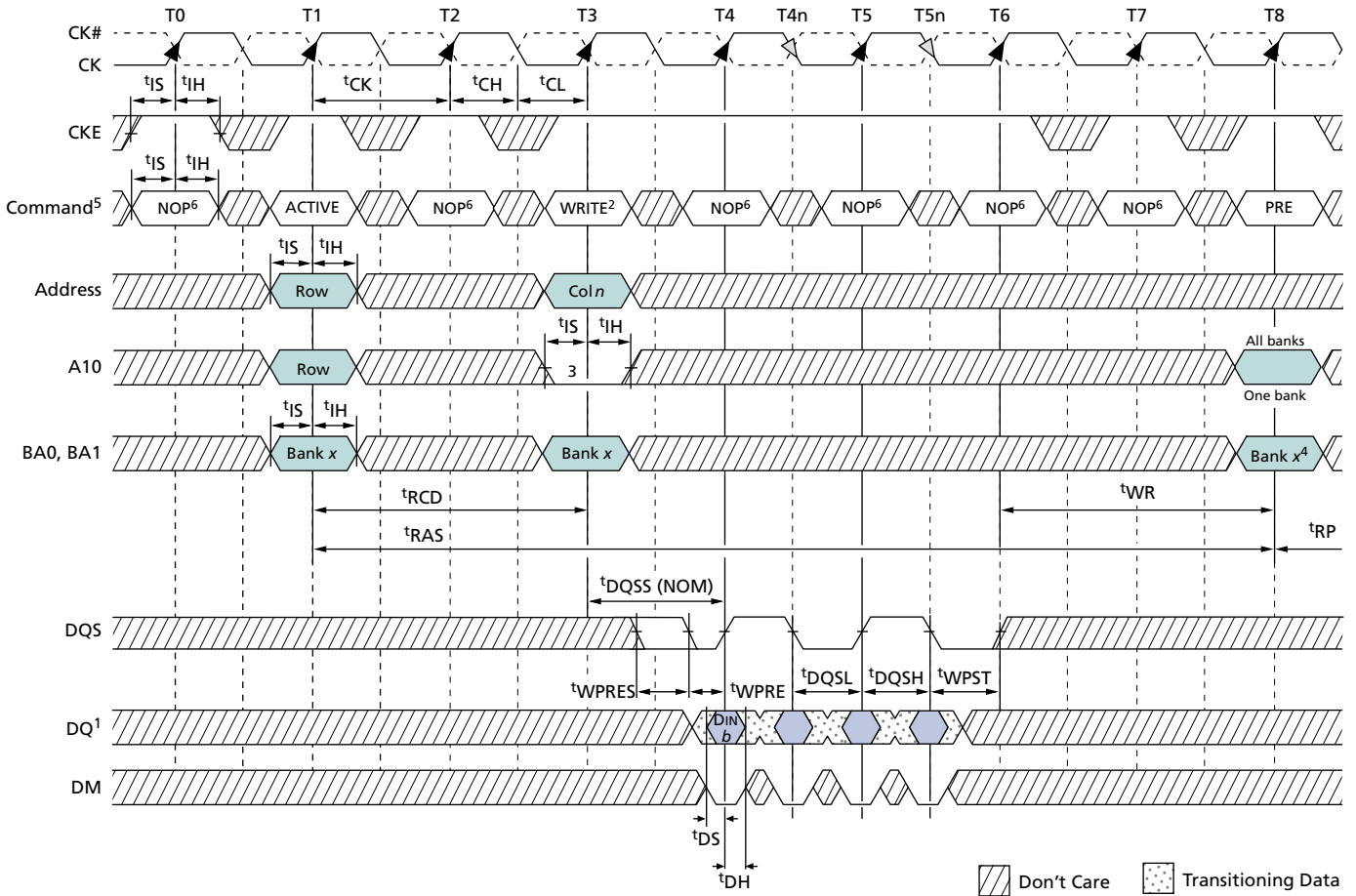

- Notes:
1. DIN n = data-out from column n .
 2. BL = 4 in the case shown.
 3. Enable auto precharge.
 4. NOP commands are shown for ease of illustration; other commands may be valid at these times.

Figure 46: Bank Write – Without Auto Precharge

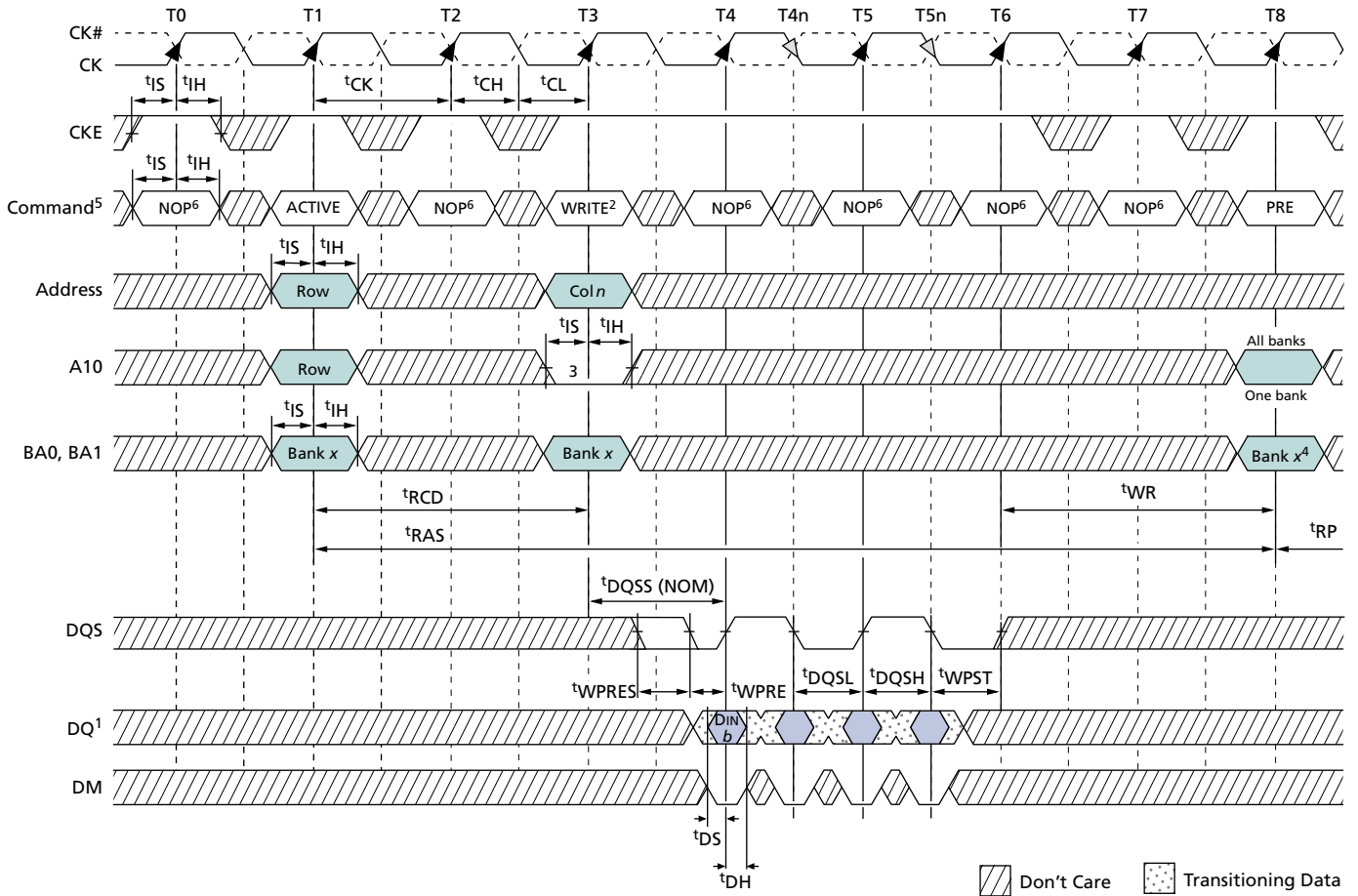

- Notes:
1. DOUT n = data-out from column n .
 2. BL = 4 in the case shown.
 3. Disable auto precharge.
 4. Bank x at T8 is "Don't Care" if A10 is HIGH at T8.
 5. PRE = PRECHARGE.
 6. NOP commands are shown for ease of illustration; other commands may be valid at these times.

Auto Refresh

Auto refresh mode is used during normal operation of the Mobile DDR SDRAM and is analogous to CAS#-BEFORE-RAS# (CBR) REFRESH in FPM/EDO DRAMs. The AUTO REFRESH command is nonpersistent and must be issued each time a refresh is required.

The addressing is generated by the internal refresh controller. This makes the address bits a “Don’t Care” during an AUTO REFRESH command.

For improved efficiency in scheduling and switching between tasks, some flexibility in the absolute refresh interval is provided. The auto refresh period begins when the AUTO REFRESH command is registered and ends t_{RFC} later.

Figure 47: Auto Refresh Mode

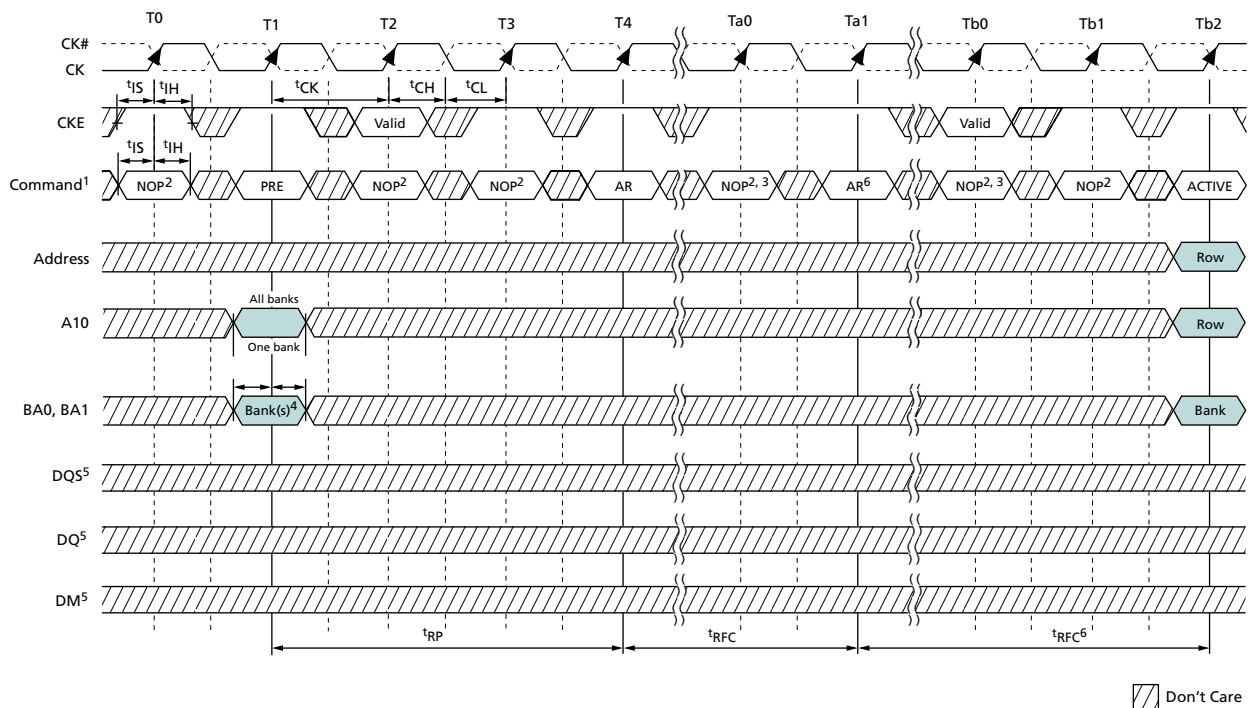

- Notes:
1. PRE = PRECHARGE; AR = AUTO REFRESH.
 2. NOP commands are shown for ease of illustration; other valid commands may be possible at these times. CKE must be active during clock positive transitions.
 3. NOP or COMMAND INHIBIT are the only commands supported until after t_{RFC} time; CKE must be active during clock positive transitions.
 4. Bank x at $T1$ is “Don’t Care” if A10 is HIGH at this point; A10 must be HIGH if more than one bank is active (for example, must precharge all active banks).
 5. DM, DQ, and DQS signals are all “Don’t Care”/High-Z for operations shown.
 6. The second AUTO REFRESH is not required and is only shown as an example of two back-to-back AUTO REFRESH commands.

Although it is not a JEDEC requirement, CKE must be active (HIGH) during the auto refresh period to provide support for future functional features. The auto refresh period begins when the AUTO REFRESH command is registered and ends t_{RFC} later.

Self Refresh

The self refresh mode can be used to retain data in the Mobile DDR SDRAM even if the rest of the system is powered down. When in the self refresh mode, the Mobile DDR SDRAM retains data without external clocking. The SELF REFRESH command is initiated like an AUTO REFRESH command, except that CKE is disabled (LOW). All command and address input signals except CKE are “Don’t Care” during SELF REFRESH. See Figure 48 on page 80 for details on entering and exiting self refresh mode. During SELF REFRESH, the device is refreshed as identified in the extended mode register (see PASR section on page 47).

The procedure for exiting SELF REFRESH requires a sequence of commands. First, CK must be stable prior to CKE going back HIGH. When CKE is HIGH, the Mobile DDR SDRAM must have NOP commands issued for t_{XSR} to complete any internal refresh already in progress.

During SELF REFRESH operation, refresh intervals are scheduled internally and may vary. These intervals may be different than the specified t_{REFI} time. For this reason, the SELF REFRESH command must not be used as a substitute for the AUTO REFRESH command.

Figure 48: Self Refresh Mode

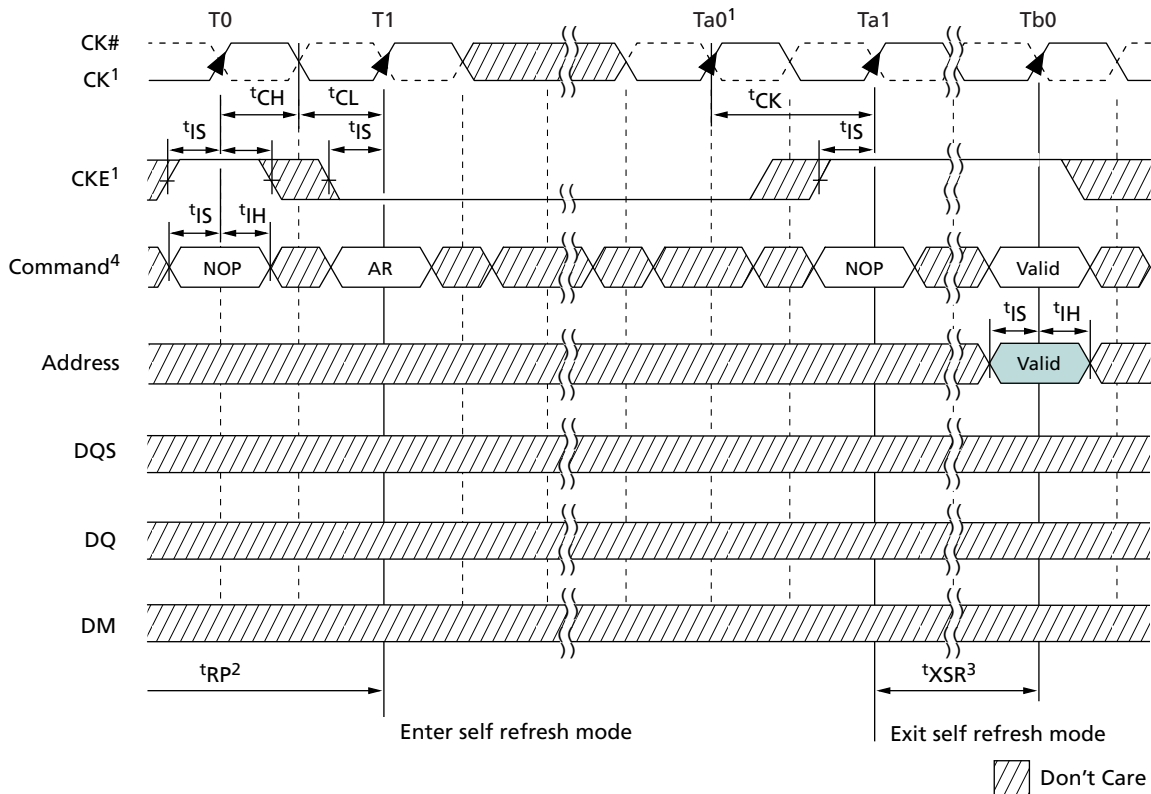

- Notes:
1. Clock must be stable, cycling within specifications by Ta_0 , before exiting self refresh mode.
 2. Device must be in the all banks idle state prior to entering self refresh mode.
 3. NOPs or DESELECTs is required for t_{XSR}^3 time with at least two clock pulses.
 4. AR = AUTO REFRESH.
 5. CKE must remain LOW to remain in self refresh.

Power-Down

Power-down (Figure 49 on page 81) is entered when CKE is registered LOW. If power-down occurs when all banks are idle, this mode is referred to as precharge power-down; if power-down occurs when there is a row active in any bank, this mode is referred to as active power-down. Entering power-down deactivates all input and output buffers, including CK and CK# and excluding CKE. Exiting power-down requires the device to be at the same voltage as when it entered power-down and received a stable clock.

Note: The power-down duration is limited by the refresh requirements of the device.

While in power-down, CKE LOW must be maintained at the inputs of the Mobile DDR SDRAM, while all other input signals are “Don’t Care.” The power-down state is synchronously exited when CKE is registered HIGH (in conjunction with a NOP or DESELECT command). NOP or DESELECT commands must be maintained on the command bus until t_{XP} is satisfied. See Figure 50 on page 82 for a detailed illustration of the power-down command.

Figure 49: Power-Down Command (in Active or Precharge Modes)

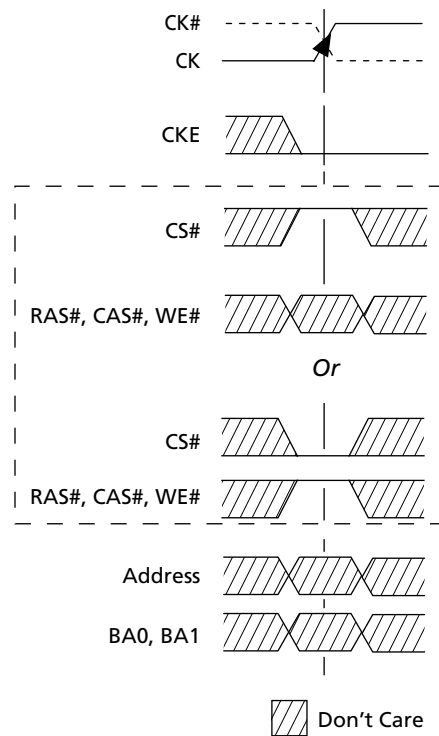
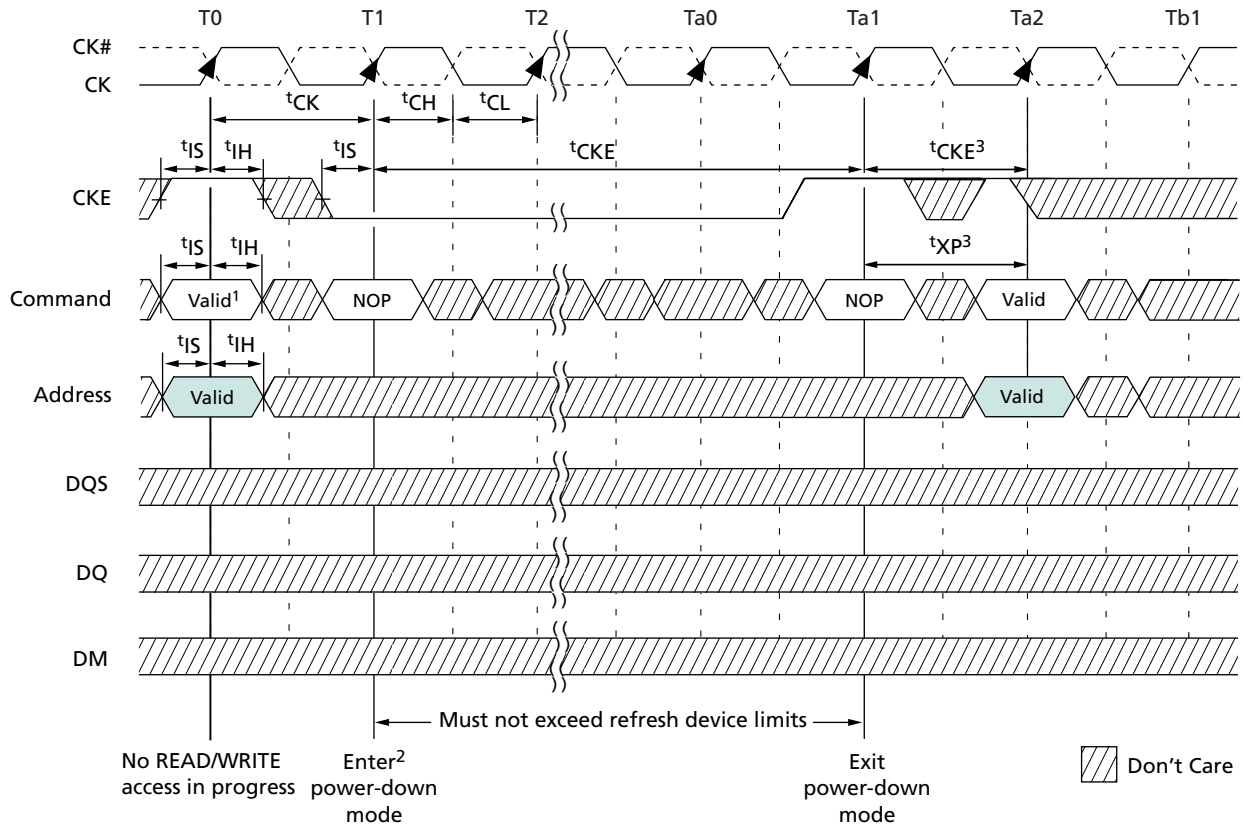

Figure 50: Power-Down Mode (Active or Precharge)



- Notes:
1. If this command is a PRECHARGE (or if the device is already in the idle state), then the power-down mode shown is precharge power-down. If this command is an ACTIVE (or if at least one row is already active), then the power-down mode shown is active power-down.
 2. No column accesses can be in progress when power-down is entered.
 3. t_{CKE}^1 applies if CKE goes LOW at $Ta2$ (entering power-down); t_{XP}^3 applies if CKE remains HIGH at $Ta2$ (exit power-down).

Deep Power-Down (DPD)

Deep power-down is an operating mode used to achieve maximum power reduction by eliminating the power of the memory array. Data will not be retained after the device enters DPD mode.

Before entering DPD mode the DRAM must be in all banks idle state with no activity on the data bus (t_{RP} time must be met). This mode is entered by holding CS# and WE# LOW with RAS# and CAS# HIGH at the rising edge of the clock while CKE is LOW. CKE must be held LOW to maintain DPD mode. The clock must be stable prior to exiting DPD mode. This mode is exited by asserting CKE HIGH with either a NOP or DESELECT command present on the command bus. Upon exiting DPD mode, a full DRAM initialization sequence is required.

Figure 51: Deep Power-Down

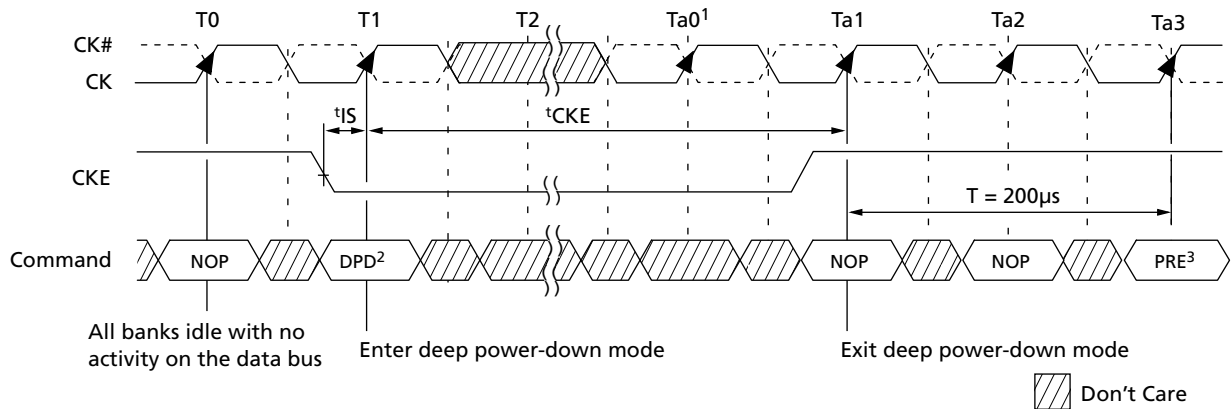

- Notes:
1. Clock must be stable prior to CKE going HIGH.
 2. DPD = deep power-down.
 3. Upon exit of deep power-down mode, a full DRAM initialization sequence is required.

Stopping the External Clock

One method of controlling the power efficiency in applications is to throttle the clock that controls the DDR SDRAM. The clock may be controlled in two ways:

- Change the clock frequency
- Stop the clock.

The Mobile DDR SDRAM enables the clock to change frequency during operation only if all the timing parameters are met and all refresh requirements are satisfied.

The clock can be stopped altogether if there are no DRAM operations in progress that would be affected by this change. Any DRAM operation already in process must be completed before entering clock stop mode; this includes the following timings: t_{RCD} , t_{RP} , t_{RFC} , t_{MRD} , t_{WR} , and t_{RPST} . In addition, any READ or WRITE burst in progress must be complete as defined in the “READS” section on page 51 and the “WRITES” section on page 62.

CKE must be held HIGH with CK = LOW and CK# = HIGH for the full duration of the clock stop mode. One clock cycle and at least one NOP or DESELECT is required after the clock is restarted before a valid command can be issued. Figure 52 on page 84 illustrates the clock stop mode.

Figure 52: Clock Stop Mode

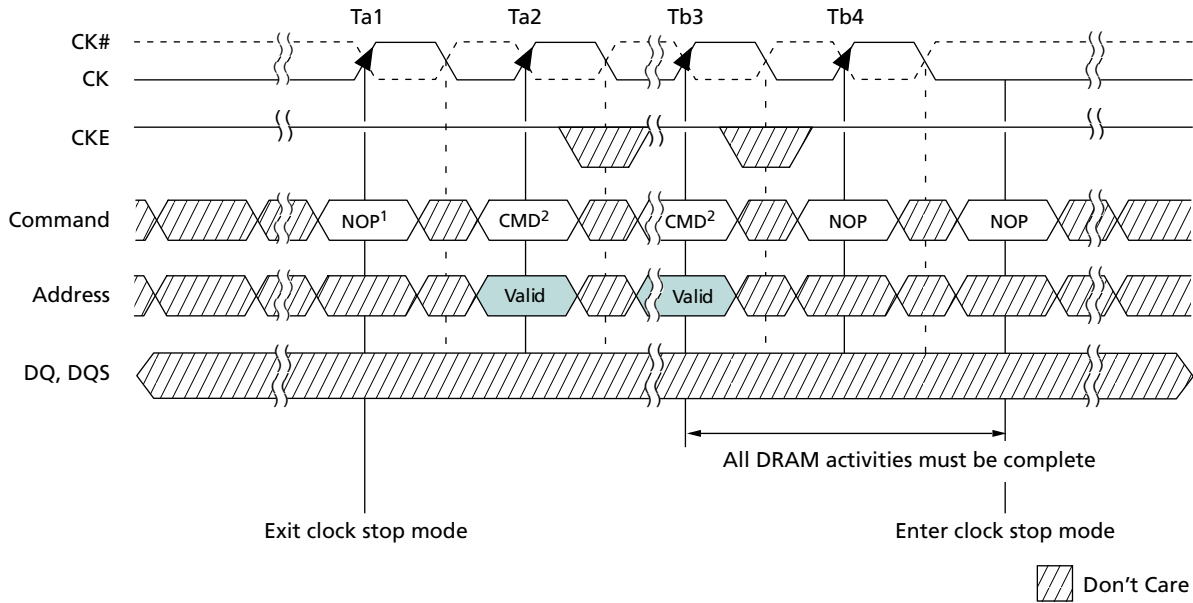

- Notes:
1. Prior to Ta1, the device is in clock stop mode. To exit, at least one NOP is required before any valid command.
 2. Any valid command is supported; device is not in clock suspend mode.



8000 S. Federal Way, P.O. Box 6, Boise, ID 83707-0006, Tel: 208-368-3900
 prodmktg@micron.com www.micron.com Customer Comment Line: 800-932-4992
 Micron, the M logo, and the Micron logo are trademarks of Micron Technology, Inc.
 All other trademarks are the property of their respective owners.

This data sheet contains minimum and maximum limits specified over the power supply and temperature range set forth herein. Although considered final, these specifications are subject to change, as further product development and data characterization sometimes occur.

Revision History: Device

Rev. G	6/08
<ul style="list-style-type: none"> • Table 10, Electrical Characteristics and Recommended AC Operating Conditions <ul style="list-style-type: none"> – Tightened ^tRFC to 110ns from 125ns. • Updated “Commands, Operations, and Timing Diagrams” sections to 5.08 update. • Updated IDD specifications <ul style="list-style-type: none"> – Table 7, “Idd Specifications and Conditions (x16),” on page 17 and Table 8, “Idd Specifications and Conditions (x32),” on page 18: Updated IDD2N and IDD2NS specifications for -75 and -6 speed grade options. – Table 9, “Idd6 Specifications and Conditions,” on page 19: Updated 85°C standard specifications for full, half, and quarter-array PASR operation. 	
Rev.F	04/08
<ul style="list-style-type: none"> • Added “L” low-power option <ul style="list-style-type: none"> – Figure 1: “1Gb Mobile DDR Part Numbering,” on page 5: Updated to include low-power option. – Table 9, “Idd6 Specifications and Conditions,” on page 19: Updated to include low-power option values. – Table 9, “Idd6 Specifications and Conditions,” on page 19: Removed 70°C and 15°C values as they are redundant and provided in Figure 8: “Typical Self Refresh Current vs. Temperature,” on page 20. 	
Rev. E	3/08
<ul style="list-style-type: none"> • “Features” on page 1: Added burst length of 16 and note reference. • Table 6, “Capacitance (x16, x32),” on page 16: Updated values. • Table 7, “Idd Specifications and Conditions (x16),” on page 17; Table 8, “Idd Specifications and Conditions (x32),” on page 18; Table 9, “Idd6 Specifications and Conditions,” on page 19; and Table 10, “Electrical Characteristics and Recommended AC Operating Conditions,” on page 21: Added -5 and -54 speed grades. • Table 12, “Target Output Drive Characteristics (Three-Quarter Strength),” on page 26: Added table. 	
Rev. D	2/08
<ul style="list-style-type: none"> • Deleted reference to Endur-IC on page 1. 	
Rev. C	9/07
<ul style="list-style-type: none"> • Changed the data sheet to “Production” status • Updated Figure 6: “60-Ball VFPGA Package,” on page 12 and Figure 7: “90-Ball VFPGA Package,” on page 13 • Table 7, “Idd Specifications and Conditions (x16),” on page 17: Changed the following specifications: IDD0 -6 to 70mA, -75 to 60mA; IDD2N -6 to 16mA, -75 to 14mA; IDD2NS -6 to 12mA, -75 to 10mA; IDD3N -6 to 18mA, -75 to 16mA; IDD3NS -6 to 14mA, -75 to 12mA; IDD4R -6 to 115mA, -75 to 105mA; IDD4W -6 to 115mA, -75 to 105mA; IDD5 -6 to 140mA, -75 to 140mA • Table 8, “Idd Specifications and Conditions (x32),” on page 18: Changed the following specifications: IDD0 -6 to 100mA, -75 to 70mA; IDD2N -6 to 16mA, -75 to 14mA; IDD2NS -6 to 12mA, -75 to 10mA; IDD3N -6 to 18mA, -75 to 16mA; IDD3NS -6 to 14mA, -75 to 12mA; IDD4R -75 to 120mA; IDD4W -6 to 140mA, -75 to 120mA; IDD5 -6 to 140mA, -75 to 140mA • Table 9, “Idd6 Specifications and Conditions,” on page 19: Replaced “TBDs” with values. 	



- Table 10, “Electrical Characteristics and Recommended AC Operating Conditions,” on page 21: Changed t_{XP} to 25ns for -6 and -75.

Rev. B 7/07

- Restructured into separate core and density documents

Rev. A 2/07

- Initial revision

Revision History: Commands, Operations, and Timing Diagrams

Update	<ul style="list-style-type: none"> • Table 17, “Truth Table – Current State Bank n – Command to Bank m,” on page 37: Corrected note 3b, changed “disabled” to “enabled.” • “Auto Precharge” on page 74: Added third paragraph regarding ^tRAS lock-out. • Figure 46: “Bank Write – Without Auto Precharge,” on page 78: Corrected note 4. 	5/08
Update	<ul style="list-style-type: none"> • “Functional Description” on page 28, Figure 18: “Extended Mode Register,” on page 48, and throughout document as appropriate: Added BL 16. • Table 19, “Burst Definition Table,” on page 45: Added BL 16 content. • “Output Drive Strength” on page 47: Added three-quarter drive strength and deleted one-eighth drive strength. Updated to include 37 ohm (deleted 100 ohm). • Figure 18: “Extended Mode Register,” on page 48: Removed E7 column and updated valid column heading to E7–E0; expanded driver strength section to include three-quarter drive strength. • Updated note 2: <ul style="list-style-type: none"> – Figure 22: “Consecutive READ Bursts,” on page 53 – Figure 23: “Nonconsecutive READ Bursts,” on page 54 – Figure 24: “Random READ Accesses,” on page 55 – Figure 25: “Terminating a READ Burst,” on page 56 – Figure 27: “READ-to-PRECHARGE,” on page 58 • Updated note 3: <ul style="list-style-type: none"> – Figure 26: “READ-to-WRITE,” on page 57 – Figure 36: “Random WRITE Cycles,” on page 67: • Removed former final note in each case: <ul style="list-style-type: none"> – Figure 38: “WRITE-to-READ – Interrupting,” on page 69 – Figure 39: “WRITE-to-READ – Odd Number of Data, Interrupting,” on page 70 – Figure 41: “WRITE-to-PRECHARGE – Interrupting,” on page 72 • Figure 42: “WRITE-to-PRECHARGE – Odd Number of Data, Interrupting,” on page 73: Extended ^tWR to coincide with T5 transition. • “Concurrent Auto Precharge” on page 74: Updated figure references. 	3/08
Update	<ul style="list-style-type: none"> • Figure 18: “Extended Mode Register,” on page 48: Updated to include mid-strength driver information. • Figure 20: “Status Register Definition,” on page 50: Corrected headings for density. 	12/07
Update	<ul style="list-style-type: none"> • Initial release. 	07/07